



euroclear

December 2010

Enhancing DBV Functionality

New Term DBV Service

Version 2.0

© 2010 Euroclear UK & Ireland Limited is incorporated in England and Wales under registered number 2878738, with registered address at 33 Cannon Street, London EC4M 5SB, United Kingdom – Tel: +44 (0)20 7849 0000 www.euroclear.co.uk – Euroclear UK & Ireland Limited is the operator of the CREST settlement system – Euroclear is the marketing name for the Euroclear System, Euroclear plc, Euroclear SA/NV and their affiliates.

www.euroclear.com

Contents

Preface	5
Glossary, abbreviations and acronyms	6
Section 1: Introduction	7
<i>Background</i>	7
<i>Message Descriptions</i>	7
<i>Term DBV overview</i>	7
<i>Enhancements</i>	9
Section 2: Changes to Deliveries By Value	10
<i>Inputting a Term DBV instruction</i>	10
<i>DBV Instruction Details enquiry</i>	11
<i>DBV Instruction List enquiry</i>	11
<i>Amending and deleting a Term DBV instruction</i>	12
<i>DBV Stock Valuation</i>	12
<i>DBV Allocation Queue</i>	12
<i>Settlement of a Term DBV input</i>	13
<i>Term DBV tolerance</i>	14
<i>Exclusion of securities from Term DBV</i>	14
<i>DBV instruction status values</i>	15
Section 3: Collateral balance and exposure enquiries	16
<i>Collateral balance</i>	16
<i>Exposure enquiries</i>	18
<i>Exposure Summary enquiry</i>	19
<i>Exposure Details enquiry</i>	19
Section 4: Term DBV transactions	20
<i>New transaction types</i>	20
<i>New transaction statuses</i>	21
<i>Term DBV Outbound Transaction (TDO)</i>	21
<i>Term DBV return transaction (TDR)</i>	21
<i>Changes to the DBV Stock Movement Retrieve enquiry</i>	22
<i>Transaction status values</i>	23
Section 5: Term DBV interest accrual	25
<i>Transferring accrued interest</i>	25
<i>Calculating accrued interest</i>	25
<i>Term DBV interest payment transaction (TDI)</i>	26

Section 6: Changing Term DBV attributes	28
<i>Collateral Amendment Instruction</i>	28
<i>Early return functionality</i>	29
<i>Accrued interest calculation for roll-overs and early returns</i>	29
<i>Collateral Instruction List enquiry</i>	30
<i>Collateral Return List enquiry</i>	36
Section 7: Manual Adjustments of Term DBV Collateral	38
<i>Manual Substitutions</i>	38
<i>Collateral Management Manual Substitution Input (ASBN) Instruction</i>	39
<i>Term DBV Manual Substitution Transaction (TDS)</i>	41
<i>Settlement of TDS transactions</i>	41
<i>Amendment and deletion of TDS substitutions</i>	44
<i>TDS transaction status values</i>	45
Section 8: Automatic Substitutions	46
<i>Overview</i>	46
<i>Term DBV Giver Recall (TDG) substitutions</i>	46
<i>Term DBV Eligibility (TDE) Substitutions</i>	55
Section 9: Mark-to-market adjustments	61
<i>Overview of the mark-to-market functionality</i>	61
<i>Mark-to-market threshold</i>	61
<i>Generation of Mark-to-Market Transactions (TDMs)</i>	62
<i>Settlement of TDM transactions</i>	64
<i>Re-apportionment of consideration</i>	65
<i>Amend and delete the TDM transactions</i>	66
<i>TDM transaction status values</i>	66
Section 10: Corporate action processing	68
<i>Generic Corporate Action Types</i>	68
<i>General principles for Term DBVs</i>	68
<i>Gilts processing</i>	70
<i>Eligible Debt Securities (EDSs)</i>	70
Section 11: Claims processing	71
Section 12: Automatic transformations	72
<i>Mandatory reorganisation</i>	72
<i>Mandatory reorganisations with options</i>	75
<i>Skipping transformations</i>	75
<i>Call payments</i>	75

Section 13: Gilts Processing	77
<i>End of day record</i>	77
<i>Gilt Interest and Redemption Payment mechanism</i>	77
<i>Claims on Gilts</i>	77
<i>Transformations on Gilts</i>	78
Section 14: Miscellaneous	79
<i>CREST system diary for Term DBVs</i>	79
<i>Settlement discipline</i>	79
<i>SDRT</i>	79
<i>US securities</i>	79
Section 15: Adjustments to DBV Value Sought and Consideration	80
<i>Term DBV Adjustment List enquiry</i>	80
<i>Term DBV Adjustment Details enquiry</i>	81
<i>Inputting a Term DBV Adjustment instruction</i>	82
<i>Settlement of a Term DBV Adjustment instruction</i>	84
<i>Amending and Deleting a Term DBV Adjustment instruction</i>	85
<i>TDA status values</i>	85
<i>DBV Instruction List Enquiry</i>	86
<i>Term DBV Transaction List enquiry</i>	86
<i>Transaction Management functions</i>	87
Section 16: Valuation of DBVs using Bank of England Haircuts	88
<i>DBV Instruction Input</i>	89
<i>DBV Instruction Details enquiry</i>	89
<i>DBV Stock Allocation</i>	89
<i>DBV Stock Valuation</i>	89
<i>Collateral Instruction List enquiry</i>	90
<i>Collateral Return List enquiry</i>	90
<i>Exposure Enquiries</i>	90
<i>Manual Substitution of Term DBV Collateral</i>	91
<i>Intraday Substitution of Term DBV Collateral</i>	91
<i>Overnight Substitutions</i>	91
<i>Mark-to-Market Adjustments</i>	92

Preface

This White book describes the enhancements planned for the CREST system for the end of June 2011. The main changes being made include:

- additional functionality to provide members of Euroclear UK & Ireland an option to create and manage Term DBVs;
- enhancements to the existing Overnight DBV and Repo functionality to further support Term DBVs;
- changes to Gilts processing, including a change to the timing of when the record is struck for Gilts.

Note: The planned changes will affect all holders of Gilts, not just those using the DBV service.

These enhancements have been developed following:

- a consultation period undertaken with the market; and
- conclusions drawn from several meetings of the Working Group.

This White book should be read with the appropriate Data Exchange Manual, which will provide the necessary technical description of the enhancements being made.

The following documents (updated versions to be issued with the Term DBV service) may also be of interest for this service description:

- *CREST Reference Manual*
- *CREST White book – CREST diary events and the daily timetable*
- *CREST White book – Monitoring transactions in CREST*

Glossary, abbreviations and acronyms

Adjusted market value	Represents the value of the collateral in a Term DBV, adjusted to exclude the value of any extra collateral needed to satisfy any applicable DBV Margin or BoE Haircut.
Centrally Excluded Collateral	Eligible collateral held in a Term DBV but selected for central substitution by the CREST system; e.g. if the collateral security is maturing, or if the collateral security has an imminent mandatory corporate action that could impact the collateral security.
CPU	Claims Processing Unit
DBV	Delivery By Value <i>Unless otherwise specified, 'DBV' refers to both Overnight DBVs and Term DBVs.</i>
DBV Instruction	Instruction input by a member to create a Term DBV or an Overnight DBV in the CREST system For ease of understanding, this White book will use: <ul style="list-style-type: none"> • 'Term DBV Instruction' to refer to Term DBVs; and • 'Overnight DBV Instruction' to refer to Overnight DBVs
DEL	Standard participant to participant delivery transaction (of one stock and/or one cash movement).
Diary Event	The CREST system uses diary events to activate automatic processes that must run, for example, on daily and periodic basis.
DvD	Delivery versus Delivery (i.e. stock only)
DvP	Delivery versus Payment
EDS	Eligible Debt Securities (also known as Money Market Instruments)
FoP	Free of Payment
FT	File Transfer
Gilts	British Government Stock
QFCQ	File Changes Request Message <i>This is an existing FT request message used by members to view changes to data (e.g. status changes) in the CREST system.</i>
RPS	Open/Term Repo Substitution transaction
SCR	Self-Collateralising Repo
TDA Instruction	Instruction input by a member to amend the DBV Value Sought and/or Consideration of a Term DBV, and, in the event of over or under collateralisation of a Term DBV, to allow the member to realign the value of the collateral in the Term DBV to be correctly collateralised.
Term DBV	A Term DBV will be managed in the CREST system by the following set of transactions: <ul style="list-style-type: none"> TDO - Term DBV Outbound TDR - Term DBV Return TDI - Term DBV Interest Payment TDG - Term DBV Giver Recall (automatic, intraday) TDE - Term DBV Eligibility (automatic, overnight) TDS - Term DBV Substitution (manual) TDM - Term DBV Mark-to-Market (automatic, overnight) TDA – Term DBV Adjustment

Section 1: Introduction

Background

Collateral transfer functionality in the CREST system is currently provided through the following collateral management services:

- Self-Collateralising Repo (SCR) service for the generation of intraday sterling liquidity from the Bank of England
- Repo (RPO) transaction service
- Overnight Delivery By Value (DBV) service

To offer the market greater flexibility in collateral management, we will extend the range of collateral management services offered by the CREST system to introduce a Term DBV service (by reusing and extending existing functionality).

The Term DBV service will be offered in addition to the existing Overnight DBV service, making it possible for members to hold DBVs with maturities of up to two years¹. It will also be possible to hold Term DBVs with one-day maturities, thereby allowing members to use the one service only, should they choose to do so.

Message Descriptions

This white book provides a description of messages changing and new messages being introduced with the Term DBV service. For the exact field names and definition of the templates, refer to the appropriate Data Exchange Manual.

Term DBV overview

Term DBVs should be viewed in the same way as existing overnight DBVs, but with an end date (plus some additional functionality to help maintain the collateral value in the DBV throughout its term).

Although the Term DBV service will be distinct from the Overnight DBVs, it is essentially an extension of that service. Other than the enhancements that have been outlined in this White book, unless explicitly stated otherwise, a Term DBV will share all the current attributes applicable to an Overnight DBV.

A Term DBV instruction is an instruction from a member to the CREST system, requesting it to assemble a package of securities of a specified type and a nominated value from a specified member account, to pass to another member as collateral in exchange for an agreed consideration or as a free of payment delivery for an agreed period of time. Full legal title to the securities passes to the Collateral Taker on settlement.

The following attributes and conditions will be applicable to the Term DBV service offered by Euroclear UK & Ireland:

¹ Members will be able to hold Term DBVs for longer durations by means of rolling the return date of the Term DBV (see Section 6)

- Term DBVs may only be input² for matching and settling (the outbound transaction) on the same day.
- A Term DBV may have a maturity period from one day to two years.
Note: Members will be able to extend the duration of a Term DBV by rolling the Term DBV return date (See Section 6).
- A Term DBV may be against GBP, EUR or USD consideration, or free of payment.
- As with Overnight DBVs, members will be able to specify an applicable margin on the collateral delivered to a Collateral Taker in a Term DBV. Additionally with the Term DBV service, members will have the option to use Bank of England haircut rates instead of a DBV Margin (For both Overnight and Term DBVs – see Section 16).
- Term DBVs will use the same set of DBV classes currently available for Overnight DBVs.
- As with Overnight DBVs, members will have the option to set a concentration limit for a Term DBV. Currently, this limits any one constituent security to **10%** of the DBV Value Sought (**including any applicable DBV Margin or BoE Haircut**³). For example, if a DBV is set up with a DBV Value Sought of GBP 500m and an 8% margin is applicable, the concentration limit applicable to each of the constituent will be GBP 54m. The concentration limit will be respected by all Term DBV functionality except manual substitutions. In the case of manual substitutions, there will be no central validation to ensure that the instructions received adhere to the concentration limit (See Section 7).
- Collateral securities for a Term DBV will be chosen centrally by the CREST system using the existing algorithm used in Overnight DBVs. A maximum of 99 lines of securities may be allocated on the initial setup of a Term DBV. This limit may, however, be exceeded as a result of the Term DBV substitution and mark-to-market functionality (See Sections 7 to 9). In this case, no upper limit will apply.
- Upon Term DBV input and successful settlement of the Term DBV outbound transaction (TDO), there will be a central generation of a set of Term DBV return (TDR) transactions (to return the collateral), and, where applicable, a Term DBV interest payment transaction (TDI) in favour of the Collateral Taker (See Section 4);
- During the life⁴ of a Term DBV, the constituents (collateral securities) of the Term DBV will be represented in the CREST system by the unsettled Term DBV return (TDR) transactions.
- Term DBVs will have substitution functionality (both automatic and manual) to maintain the constituent securities of a Term DBV (See Sections 7 and 8);
- There will be an end-of-day automatic mark-to-market adjustment functionality to centrally ensure that the daily value of the collateral for a Term DBV remains aligned to the original value sought, plus any margin (See Section 9);
- Members will be able to amend the interest rate and return date attributes of a Term DBV (See Section 6). Members will also be able to amend the DBV value sought and consideration attributes of a Term DBV – this is described in a separate standalone section (See Section 15).

² Input of Term DBVs in the CREST system will be during the same diary window as Overnight DBVs (i.e. from the system opening at 04:00 to 16:02 GMT, i.e. before the end of DBV settlement).

³ **Note:** The functionality for Term DBVs using the Bank of England haircut option is described in a separate standalone section (See Section 16).

⁴ The period of the Term DBV arrangement.

Enhancements

This White book describes the following enhancements to the CREST system:

Enhancement described in this White book	Refer to
Management of Term DBV instruction and transactions	Sections 2 and 4
Enhanced DBV Stock Valuation , DBV Allocation Queue and Exposure enquiries	Section 3
Enhanced Stock Account Balance enquiry to also show balances by collateral usage. The enhanced response message will include two new balance fields, Collateral In and Collateral Out	Section 3
An enquiry function, Open Collateral Returns , to view the list of Term DBV return transactions that make up the Collateral In and Collateral Out balances provided by the enhanced Stock Account Balance enquiry	Section 3
Central calculation and transfer of accrued interest from the Collateral Giver to the Collateral Taker	Section 5
Enhanced Repo Amend functionality to also allow change to the duration (return date) and interest rate attributes of a Term DBV	Section 6
An alert mechanism to flag Term DBV collateral that needs members attention. For example, if constituent security has become ineligible and could not be centrally replaced by the CREST system	Sections 6, 8 and 9
Manual substitution functionality to allow members to maintain securities in a Term DBV on an ad-hoc basis	Section 7
Central generation of intraday substitutions (to recall collateral securities out on Term DBV) to settle a failing market transaction (delivering security)	Section 8
Central generation of overnight substitutions to replace constituent securities in a Term DBV that must be substituted out	Section 8
Central generation of overnight mark-to-market adjustment transactions to automatically align the Term DBV collateral against the original value sought, plus any margin on a daily basis	Section 9
Central processing to handle the impact of corporate actions on the Term DBV constituents	Sections 10 to 13
Functionality to manage the DBV Value Sought and Consideration attributes of a Term DBV	Section 15
Valuation of DBVs using the Bank of England haircut rates	Section 16

Section 2: Changes to Deliveries By Value

The Term DBV service, where possible, will utilise existing DBV functionality (both GUI and file transfer) that is currently available for Overnight DBVs.

The Term DBV service is offered in addition to the Overnight DBV service. Therefore, members that do not want to use Term DBVs, may still continue to use Overnight DBVs.

The enhancements needed to the existing functionality are described in this section.

For Term DBVs using the Bank of England haircut option, also refer to Section 16, which describes additions to some of the functions described in this section.

Inputting a Term DBV instruction

Members will be able to set up Term DBVs in the CREST system using the existing **DBV Input Instruction (NDDN)** message.

To facilitate Term DBV input, the NDDN instruction will be enhanced to include a new field, called **Return Date**. The presence of a return date in the DBV Input instruction will indicate to the CREST system that the instruction is for a Term DBV. More information is provided below.

The possible fields that may be completed in the enhanced NDDN⁵ message will therefore be as follows:

- **Return Date** (optional). Specifies the intended settlement date of the DBV return. Both parties must match this field exactly (if either party inputs it) and therefore it will not match to a blank. Including a return date will indicate the input of a Term DBV instruction. If no return date is included, it will indicate the input of an Overnight DBV instruction. If the return date is included, it must be greater than the current working date and not be forward-dated more than two years. It will be possible to specify a return date of the next business day so as to effectively set up an 'overnight' Term DBV⁶
- DBV Reference (mandatory)
- Trade System of Origin (optional, requires matching)
- DBV Class (mandatory, requires matching)
- DBV Concentration Limit (mandatory, requires matching)
- DBV Margin (optional, requires matching)
- Currency Code (mandatory for interactive users, requires matching)
- DBV Value Sought (mandatory, requires matching)
- Payment Type (optional, requires matching)
- Consideration (optional, requires matching)
- Participant Note (optional)
- DBV Interest Rate (optional, requires matching)
- Priority (optional). This will continue with the current default of 50

⁵ Members should refer to existing Euroclear UK & Ireland publications for a full description of the current fields applicable to DBV Input.

⁶ Members should be aware that the return date is a matching field and that even for DBVs with one-day maturities, the counterparty to the DBV will need to use the same service, i.e. a DBV input for the Term DBV service will not match a DBV input for the Overnight DBV service.

- Dealing Capacity (optional)
- MMI Issuer ID (optional, requires matching)
- Transaction Report Marker (mandatory)
- Sundry Transaction Information (optional)
- **Mark To Market** (optional new field, included in the message for future use; currently will always be set to Yes)⁷
- **Apply BoE Haircut** (optional new field, applicable in the case where a Term DBV needs to be valued by applying the Bank of England haircuts, see Section 16)
- Participant ID (mandatory, requires matching, occurs twice)
- Account ID (mandatory, occurs twice)
- Nationality Declaration (mandatory, occurs twice)
- Shared Note (optional, occurs twice)
- Giver or Taker (mandatory, occurs twice)

DBV Instruction Details enquiry

The existing **DBV (Instruction) Details** enquiry will be enhanced to report Term DBVs as well as the Overnight DBVs. The enquiry is available via file transfer and GUI (**NDDQ/NDDR**).

The response message to the enquiry will be updated to include the following new fields:

- **Return Date;**
- **Apply BoE Haircut;**
- **Mark To Market** (currently always set to Yes on input)

For the GUI enquiry (NDDR), in addition to the change above, the GUI screen will be further enhanced to also show the **Intended Settlement Date** field. This is an existing field in the response message that is currently not displayed on the CREST GUI enquiry.

DBV Instruction List enquiry

Members will be able to view a list of their Term DBV instructions using the existing GUI **DBV (Instruction) List (NDDL)** enquiry.

The response message to the enquiry will be updated to include the following new fields:

- **Return Date;**
- **Transaction Type**
- **Mark To Market** (currently always set to Yes on input)

The enquiry will now show both Term DBV and Overnight DBV instructions side by side. Members will not be able to retrieve the instruction lists of the two products independently of each other, since no change is made to the selection criteria at this time. However, members will be able to easily differentiate between the Term DBV and Overnight DBV instructions by the Transaction Type field.

Also refer to Section 15 (Adjustments to DBV Value Sought and Consideration) which describes additional scope change for the NDDL instruction.

⁷ **Note:** the 'Mark to Market' field will not be available for input from the CREST GUI.

Amending and deleting a Term DBV instruction

Members will be able to amend and delete Term DBVs before settlement of the outbound transaction, via either file transfer or interactively via the GUI, using the existing:

- **DBV Instruction Amend (NDDA);** and
- **DBV Instruction Delete (NDDD)** functions.

As with the existing functionality, only non-matching fields of the Term DBV instruction will be amendable.

Term DBVs that have been input and matched, but where the outbound transaction (TDO) has not settled, may be deleted⁸ but will need both parties to input a deletion. Otherwise the Term DBV will continue to be considered for setup and settlement in the normal manner. If, at the end of day (DBV settlement window), the TDO transaction of the Term DBV still remains unsettled, the Term DBV will be rejected.

DBV Stock Valuation

The CREST system will view securities held in a member's account as a single pool of securities available for allocation for both Overnight and Term DBVs.

When using the Term DBV service, members will be able to use the existing **DBV Stock Valuation** enquiry to retrieve the value of securities held in their account that are available for use in DBVs. The value reported will be the amount that is available for use in DBVs in general (be it Overnight or Term DBV). The enquiry is available via file transfer and **GUI (NVDQ/NVTQ and NVDL/NVTR)**. Currently, access to this enquiry is only available upon request. However, with the introduction of the Term DBV service, the enquiry will be made available to all participants of the DBV service (Overnight or Term DBV).

Together with the change being made to the DBV Security Allocation process related to regulation 17A of the Securities Exchange Act for US securities (See Section 14), we will make the following additional change to the **DBV Stock Valuation** enquiry:

- When the Counterparty ID is specified as one of the selection criterion, and that party is a US participant, the enquiry will be updated to exclude all US securities from the stock valuation.

Members should also see the description applicable to DBV Stock Valuation as described in Section 16 – Valuation of DBVs using BoE Haircuts.

DBV Allocation Queue

Collateral Givers to a Term DBV will be able to use the existing **DBV Allocation Queue (NDQR)** enquiry to view, for a particular account, the list of Term DBVs that are queued for stock allocation and settlement. This enquiry is available via interactive GUI only.

The response message to the enquiry will be updated to incorporate the **Return Date** field.

This enquiry will now show both Term DBVs and Overnight DBVs side by side. Members will not be able to retrieve the lists of the two products independently of each other, since no change is made to the selection criterion at this time. However, members will be able to easily differentiate between Term DBVs and Overnight DBVs by the **Return Date** field⁹.

⁸ Members will not be able to delete matched Term DBV instructions that have created a settled Term DBV transaction.

⁹ The 'Return Date' for Overnight DBV instructions will always be blank (spaces).

Settlement of a Term DBV input

Term DBV instructions (as with Overnight DBVs) may be input and matched from the system opening at 04:00 GMT, but settlement of the outbound transactions will not be considered until after the close of standard settlement. After this, all Term DBVs (and Overnight DBVs) that have been input and matched will be processed in a specific settlement window for DBVs. The current daily timetable of the CREST system permits DBV settlement every day from 15:00 to 16:10 GMT. Term DBVs will be settled in this window along with the Overnight DBVs.

Setup and settlement of Term DBVs will follow the same process as for Overnight DBVs, as described below.

Step	Description
1	The CREST system will use the existing collateral allocation process (that is currently used for Overnight DBVs) to identify and allocate available securities from the Collateral Giver's account, taking into consideration any securities that must be excluded from the Term DBV ¹⁰ .
2	Once collateral allocation is achieved, a single Term DBV outbound (TDO) transaction is settled according to the usual constraints. The Term DBV outbound transaction will be for the delivery of the allocated lines of securities (up to a maximum of 99) making up the collateral against a single payment (where consideration is applicable).
3	At the time of settlement, the CREST system will also centrally create a set of Term DBV return (TDR) transactions, one for each Term DBV constituent (line of collateral security) to be returned. The transactions will be created pre-matched, with the intended settlement date set to the return date of the Term DBV. Note: During the life of a Term DBV, the unsettled TDR transactions will represent the Term DBV constituents.
4	If the Term DBV is against consideration, then the total consideration will be pro-rated across the TDR transactions. In pro-rating the consideration across the returns, the system will calculate the relative value of each return security making up the Term DBV (based on the price held in Euroclear UK & Ireland ¹¹) and split the Term DBV consideration in ratio of the relative value of the return security to the total Term DBV collateral value. The price used to calculate the relative value of a security will be based on the price held in the CREST system upon settlement of the Term DBV outbound transaction. If the Term DBV is free of payment, the consideration on each of the TDR transactions will be set to zero.
5	If the Term DBV specifies an applicable interest rate, the CREST system will centrally create a Term DBV interest payment (TDI) transaction. The TDI transaction will be created pre-matched, with the intended settlement date set to the return date of the Term DBV.
6	For Term DBVs where outbound transactions remain unsettled ¹² , members will be able to input replacement DBV instructions for immediate settlement until 16:02 GMT (i.e. eight minutes before DBV settlement ends).
7	At the end of the settlement window, Term DBVs with unsettled outbound transactions will be rejected.

¹⁰ The current DBV Exclusion functionality remains unchanged. Its applicability to Term DBVs is described later in this section. The DBV Security Allocation has been updated (in relation to Regulation 17A compliance), as described in Section 14.

¹¹ In line with current processing, Euroclear UK & Ireland will use the bid price for equities, the CREST reference price for EDSs, the DMO reference price for Gilts (dirty price) and the bid price for collective instruments.

¹² As per Overnight DBVs, the CREST system will generate a DBV Delay Reason Code at transaction level indicating the reason for settlement failure.

Term DBV tolerance

The DBV Security Allocation process will use the same degree of tolerance for Term DBVs as currently applies to Overnight DBVs. The tolerance value:

- is set at GBP 250; and
- will only be applicable when the Term DBV value sought is greater than GBP 1 million and is also greater than 102% of the Term DBV consideration.

All participants that are involved in Term DBVs will be subject to this tolerance matching, which is unrelated to tolerance matching of DEL, SLO and RES transactions.

Exclusion of securities from Term DBV

The current DBV exclusion functionality for the Overnight DBV service will also be applicable to the Term DBV service:

- Collateral Takers¹³ may ask CREST system Operations to exclude particular securities from the DBVs they receive, e.g., if there are legal restrictions on their holding and/or they own a particular security, where there are restrictions related to a particular counterparty or where that security has a nationality declaration requirement.
- Collateral Takers may also request to exclude all EDS securities that are issued by a specific EDS issuer.

Any exclusion requested will apply to both Overnight DBVs and Term DBVs. It will not be possible to request exclusions for the individual service.

In addition to the above exclusions, securities may also be centrally excluded from DBVs (Overnight and Term DBV) in the following situations (according to the current procedure):

- The security is set up to be excluded from DBVs; i.e., the **DBV Allowed** flag of the security is set to 'No'.
- The security has an active mandatory corporate action with a record date of today and the **DBV Exclusion** flag of that corporate action is set to 'Yes'.

For the overnight substitution functionality of the Term DBV service, as well as the above exclusions, the CREST system will also exclude securities that have an active mandatory corporate action with a record date of next business day and a **DBV Exclusion** flag that is set to 'Yes' (See Section 8).

Additionally, for DBVs (both Overnight and Term DBVs) where BoE Haircut is applicable, securities that are not eligible for use with the Self-Collateralising Repo service with the Bank of England will also be excluded (See Section 16).

¹³ As per current functionality it will not be possible for the collateral giver to exclude the use of particular securities from their collateral account; except, of course, by moving them to a separate member account.

DBV instruction status values

The Term DBV service will introduce a new DBV Party Status of **X**.

The '**X**' DBV Party Status will be used to indicate that the DBV instruction is for a Term DBV where the outbound Term DBV transaction has settled.

The DBV instruction may undergo the following status changes:

DBV instructions	You	Counterparty	Transaction	Description
	B	A	A	My input unmatched
	A	B	A	Counterparty input unmatched (alleged against me)
	I	I	E	Instructions matched and ready to action (settle)
	X	X	F	Settled – Term DBV transaction generated
	Y	Y	F	Settled – Overnight DBV transaction generated
	I	I	R	Instructions rejected. No transaction generated
	Z	Z	Z	Archived
Deletions	F	F	C	I deleted my unmatched input
	F	F	C	Counterparty deleted their unmatched input
	D	E	E	I delete a ready DBV instruction
	E	D	E	Counterparty deletes a ready DBV instruction
	F	F	C	Deletion matched, DBV instruction deleted

Note: The progress status of DBVs is reported by the CREST system through the combination of the following three values:

- **You:** denotes your input status, i.e. your DBV party status/party transaction status;
- **Counterparty:** denotes your counterparty's input status, i.e. your counterparty's DBV party status/party transaction status; and
- **Transaction:** denotes the overall DBV progress status.

Refer to the existing Euroclear UK & Ireland publication, 'Monitoring Transactions in CREST' white book for definitions of these existing instruction /transaction status values.

All status changes for the DBV instruction will be reported to members using the existing File Changes mechanism (for DBVs), i.e. via NSDQ and NSDP messages.

Section 3: Collateral balance and exposure enquiries

Collateral balance

Members are currently able to view the balance details of their account per balance type using the **Stock Account Balances** enquiry. When members use the enquiry to retrieve the Available balance details, the response currently also shows the Repo balance¹⁴; i.e. the balance of securities out on collateral (with the Bank of England) as a result of the Self-Collateralising Repo (SCR) functionality. The enquiry is available via file transfer and GUI (**BSBQ/BSBL**).

With Term DBVs, the Stock Account Balances enquiry will be enhanced so that when the request is for balance type 'Available', the response – in addition to retrieving the Available and Repo balance – will now also retrieve two new memo balances:

- Collateral In
- Collateral Out

The **Collateral In** balance will be a memo balance for information purposes only and will reflect the aggregate security balance (quantity) that the member has received and must return as a result of being a Collateral Taker on the following transactions:

- Term DBVs (TDR)
- Overnight DBVs (DBR)
- Open/Term Repos (RPR)

The **Collateral Out** balance will be a memo balance for information purposes only and will reflect an aggregate security balance (quantity) that the member has delivered out and should receive back as a result of being a Collateral Giver on the following transactions:

- Term DBVs (TDR)
- Overnight DBVs (DBR)
- Open/Term Repos (RPR)

Note: The Collateral In and Collateral Out balances report the respective collateral activity and not the actual balance. If, for example, a member receives securities, they will be shown in the **Collateral In** balance. If these securities are then delivered out as collateral by the member, they will **also** be shown by the **Collateral Out** balance.

The response message to the Stock Account Balances enquiry will therefore be updated to incorporate the following two new fields:

- Repo Balance Collateral In
- Repo Balance Collateral Out

The response message will also be updated to include a rename of the existing SCR balance field from **Repo Balance** to **Repo Balance SCR**.

¹⁴ **Note:** The Repo Balance is a memo balance for information purposes only and does not indicate any right or interest in the repo-ed securities.

Together with the enhancement to the Stock Account Balances enquiry, members will also be provided with access to a new enquiry called **Open Collateral Returns**. This new enquiry will allow members to view a list of all the return transactions (TDR, DBR and RPR) that make up the Collateral In and Collateral Out balances. The enquiry will be available via both file transfer and interactive GUI (**AOCQ/AOCL**).

Members will have the following selection criteria for the GUI enquiry:

- Account ID
- ISIN
- Display Sequence (the display sequence dictates the order in which the data will be retrieved and must indicate either counterparty or return date)

Members will have the following selection criteria for file transfer enquiry:

- Account ID (optional)

The response message to the enquiry will return the following list of fields:

- Participant ID
- Account ID
- Transaction ID
- Transaction Reference
- Transaction Type
- Return Date
- Counterparty ID
- Stock Debit/Credit
- ISIN
- Quantity
- Currency Code
- Consideration
- Origin Transaction ID (*FT only*)

For the CREST interactive GUI, members will be able to access the Open Collateral Returns list enquiry via a new navigation button that will be added to the Stock Account Balances List enquiry screen.

Members are currently also able to access the **Stock Postings List (DSPL)** enquiry from the Stock Account Balances List screen. This enquiry, which is also available via file transfer (**DSPQ**), allows members to retrieve the list of transactions that gave rise to the stock postings relating to the balance being viewed. The enquiry will be enhanced to cover Term DBV transactions.

Exposure enquiries

During the life of a Term DBV, the value of the collateral securities held within it may change. As a result an exposure against the **consideration** may be created between the counterparties¹⁵. However, in practice, the overnight mark-to-market process will seek to generate a mark-to-market adjustment transaction (for settlement next business day) to re-balance a Term DBV that has become under or over-collateralised. Therefore, term DBV exposures may only arise if either the mark-to-market process fails to generate the ‘adjustment’ transaction, or the ‘adjustment’ transaction fails to settle.

Members are currently able to monitor the extent of their exposure for collateral related transactions (Overnight DBVs, Open/Term Repos, and Stock Loans) using the following two exposure enquiries (available via both FT and GUI):

- Exposure Summary (BESQ/BESR)
- Exposure Details (BEDQ/BEDL)

These existing enquiries will be extended to include Term DBV transactions. *For Term DBVs using the Bank of England haircut option, also refer to Section 16, which describes use of the exposure functions connected to the BoE haircut changes.*

To determine the current value of the open collateral related transactions, the CREST system will identify all of the relating open return legs that exist between a pair of counterparties and re-calculate the value of securities held within them. This calculation will be based on the CREST system reference price as follows:

- For equities, the bid price will be used
- For Gilts, the DMO reference price will be used
- For EDSs, the CREST reference price will be used

The **Exposure** field shows exposure relative to the type of transaction. For Term DBV transactions the exposure shown will be from the perspective of the Collateral Taker.

For a Collateral Taker, the exposure to a Term DBV will be shown as negative if the value of the collateral is less than the consideration¹⁶. If the value of the collateral is greater than the consideration, the exposure will be shown as positive. For the Collateral Giver, the exposure will be the opposite.

Example

A Term DBV transaction exists between parties A and B. Party A has given cash in return for collateral from B. The Term DBV was against a consideration of GBP 1000, for which B delivered collateral with a total initial value of GBP 1100 (including margin) based on prices held in the CREST system. On settlement of this Term DBV, the enquiry will show a positive figure in the exposure field of GBP +100 for participant A, and GBP -100 for B. During the overnight processing on settlement day, a revaluation of the Term DBV against the latest prices indicates that the Term DBV is within the mark-to-market threshold and, thus, no rebalancing is performed (See Section 9).

During overnight processing on the day after settlement, revaluation of the Term DBV indicates that the new value of the collateral is GBP 850 (due to a fall in price of the security involved). However, the overnight mark-to-market process fails to generate the mark-to-market adjustment transaction (as Party B does not have the required collateral) to re-balance the Term DBV.

¹⁵ **Note:** There will always be an exposure: where the Term DBV is FOP, where the Consideration is not the same as the DBV Value Sought, or where there is an applicable DBV margin.

¹⁶ Where the Term DBV is FoP, a value of zero will be used for the consideration.

The enquiry on the following day will show a negative figure in the exposure field of GBP -150 for participant A and GBP +150 for B. The Term DBV is therefore under collateralised and Party A may choose to call for additional collateral. Party B may add the required collateral to the Term DBV intraday, using the manual substitution transaction (TDS), which is subject to Party B acquiring the required collateral. In any case, when the mark-to-market process is invoked during overnight, it will again seek to re-balance the Term DBV if it is still under collateralised.

Exposure Summary enquiry

The **Exposure Summary** enquiry provides the aggregate exposure for a given counterparty and member account. Within the enquiry, transactions of the same type and in the same direction will be aggregated. For example, if Parties A and B have two open Term DBVs (in which party B is the Collateral Taker) and one Term DBV in the opposite direction (in which party A is the Collateral Taker), the exposure will aggregate the first two transactions. The Term DBV in the opposite direction will be shown separately.

The enquiry will not display exposures across transaction types, i.e. the exposures are shown for Term DBVs, Overnight DBVs, Open/Term Repos and stock Loans separately and these are not aggregated together.

There is no change to the enquiry apart from scope. It will continue to return the following details:

- Counterparty ID
- Account ID
- Stock Debit/Credit
- Transaction Type (this will now be TDR, DBR, RPR or SLR)
- Base value of securities (this is the initial aggregate given or received for the counterparty stated, including any agreed margin);
- Total value of cash. Net given or received for the counterparty stated;
- Exposure (this field shows the total exposure that exists between the requesting participant, at the aggregate level, and the stated counterparty. This could therefore be a positive or negative value)

Exposure Details enquiry

The **Exposure Details** enquiry provides the exposure for a given counterparty and member account at the transaction level. Since the enquiry is at the transaction level they are not aggregated.

There is no change to the enquiry apart from scope. It will continue to return the following details:

- Transaction ID
- Transaction Reference
- Base Value of securities. (This is the total value of securities given or received within the open transaction, including any agreed margin)
- Total value of cash. Net given or received within the transaction stated
- Exposure (This field shows the total exposure that exists between the requesting participant, at the transaction level, and the stated counterparty. This could therefore be a positive or negative value)

Section 4: Term DBV transactions

New transaction types

The Term DBV service will introduce eight new transaction types into the CREST system:

- **TDO - Term DBV Outbound** - a Term DBV transaction that is settled to transfer allocated collateral securities from the Collateral Giver to the Collateral Taker.
- **TDR - Term DBV Return** - a Term DBV return transaction that is centrally generated (for return of a constituent security to the Collateral Giver) on settlement of the corresponding outbound transaction.
- **TDI - Term DBV Interest Payment** - a Term DBV interest payment transaction that is centrally generated (if an interest payment to the Collateral Taker was requested) on settlement of the corresponding outbound transaction.
Note: The consideration of the TDI is updated throughout the life of the Term DBV to reflect the accruing interest.
- **TDE - Term DBV Eligibility** - a Term DBV substitution transaction that is centrally generated overnight to replace collateral that is ineligible or collateral that is to be centrally excluded from a Term DBV. Collateral may become ineligible as result of some change relating to the security (e.g. change of security category) or it may need to be centrally excluded, for example, as a result of an imminent corporate action on the collateral (such as a Reorganisation event).
- **TDG - Term DBV Giver Recall** - a Term DBV substitution transaction that is centrally generated intraday to recall and replace a security out on Term DBV collateral, but which is needed to satisfy the settlement of a separate transaction (utilising the same member account as that of the Term DBV) of the Collateral Giver.
- **TDM - Term DBV Mark-To-Market** - a Term DBV transaction that is centrally generated overnight to adjust the collateral of a Term DBV for the purpose of aligning the mark-to-market valuation to the original value sought (plus any margin).
- **TDS - Term DBV Manual Substitution** - a Term DBV transaction that allows members to manually adjust (i.e. increase or decrease) or substitute (replace) the collateral in a Term DBV.
- **TDA – Term DBV Adjustment** - a Term DBV transaction that allows members to manually adjust the DBV Value Sought and Consideration attributes of a Term DBV.

Members will be able to use the existing CREST system transaction functionality (both file transfer and interactive GUI) for these new transaction types.

The descriptions of the TDO and TDR transactions are covered in this section. The remaining transactions (TDI, TDE, TDG, TDM, TDS and TDA) are covered by subsequent sections of this White book.

New transaction statuses

We will introduce a single new transaction status value of **K**.

The ‘**K**’ transaction status will apply to Term DBV transactions (TDO and TDR) if a substitution (TDE or TDM) is needed. This is a transitory¹⁷ status change. The status will be applied if the substitution is needed and regardless of whether the central generation was successful or not (See Sections 8 and 9). Manual and intraday substitutions (TDS and TDG) will not give rise to this new status change.

Note: The existing ‘**J**’ party transaction status (indicating that a substitution has occurred) will apply to the TDO transaction for all the Term DBV substitutions (TDS, TDG, TDE and TDM).

Term DBV Outbound Transaction (TDO)

Following Term DBV input, successful settlement of the Term DBV outbound (TDO) transaction will deliver the centrally allocated collateral securities from the Collateral Giver to the Collateral Taker against, where applicable, a sum of consideration. The TDO transaction will be similar to the existing Overnight DBV outbound transaction (DBV) and will contain most of the standard fields for a transaction in the CREST system.

Members will be able to view details of the TDO transaction using existing transaction-related enquiries such as **Transaction Request (ATXQ/ATXR)** and **Transaction Status Request (ATSQ)**. However, as per current GUI functionality limitations, the **Transaction Request (ATXR)** interactive GUI enquiry will only show details for up to four security movements. Members will need to use the separate GUI function, **Stock Movement List Request (NDSR)** to view details for the full set of security movements related to a TDO transaction (see the description of this enquiry later in section).

Members will not be able to amend, delete or split TDO transactions.

Note: Although amending the settled TDO transaction will not be permitted, members will be able to amend certain attributes of the Term DBV via the **Collateral Amendment Instruction** and **Term DBV Adjustment Instruction** functions (See Sections 6 and 15 for further details). For example, to return a Term DBV earlier than originally agreed, members will be able to amend the Return Date attribute of the Term DBV.

Settlement of Term DBV outbound transactions could result in the settled collateral being eligible for the Self-Collateralising Repo (SCR) functionality, which is used for raising intraday liquidity for a Collateral Taker’s settlement bank. The standard eligibility criteria for generating SCRs will need to be satisfied:

- the security involved must be eligible;
- the Collateral Taker’s account is enabled for the SCR service; and
- the consideration is Sterling and above the threshold.

Term DBV return transaction (TDR)

On settlement of the outbound transaction (TDO) of a Term DBV, the CREST system will also generate Term DBV return (TDR) transactions¹⁸ – one for each line of constituent security in the TDO to be returned.

¹⁷ ‘Transitory’ means that the status of the transaction will revert back to its earlier value once the transitory status has been applied.

¹⁸ **Note:** Unless otherwise explicitly stated, the attributes for the created TDRs will be as stated in this section (and therefore is not restated elsewhere in the white book where creating TDRs is mentioned).

If the Term DBV has a consideration, the consideration will be pro-rated across each of the TDR transactions. In pro-rating the consideration across the returns, the system will calculate the relative value of each return security making up the Term DBV and split the Term DBV consideration in ratio of the relative value of the return security to the total Term DBV collateral value. The price used to calculate the relative value of a security will be based on the price held in the CREST system on settlement of the Term DBV outbound transaction. If the Term DBV is free of payment, the consideration on each of the TDR transactions will be set to zero.

The TDR transactions will be created as matched with the intended settlement date set to the Term DBV return date, and a priority of **90**. Each TDR will be separately assessed for settlement on its intended settlement date.

The TDR transaction will be similar to the existing Overnight DBV return transaction (DBR) and will contain most of the standard fields for a transaction in the CREST system.

The **Origin Transaction ID** (set to the Transaction ID of the TDO) and **Origin Transaction Ref** (set to the Transaction Reference of the TDO) fields of the TDR will be used to link the TDR transactions of a Term DBV to the related TDO transaction.

Members will be able to use existing transaction enquiries to retrieve details of the TDR transaction.

Amending TDR transactions will be possible using the existing **Transaction Amend (ATXA)** functionality. Members will be able to amend the following fields via ATXA:

- Transaction Reference
- Participant Note
- Shared Note

In addition to the above fields, members will also be able to amend the priority of the Term DBV return transactions via the **Collateral Amendment Instruction (ARPA)** function (See Section 6).

Note: The priority of TDR transactions may only be raised or lowered as a group. Amendments to the priority of individual TDRs will not be allowed.

Members will be able to match-delete Term DBV return transactions that have not settled via the existing **Transaction Delete (ATXD)** functionality. Both parties must input the deletion, otherwise the transaction will continue to be put forward for settlement in the normal manner.

Members will be able to manually split TDR transactions using the existing split transaction functionality. It will be possible to split the TDR transactions either on the Term DBV return date or afterwards, if they still remain unsettled. TDRs will never be split automatically by the CREST system.

Term DBV return transactions will be subject to the CREST automatic transformation and claims functionality. As a result, any unsettled TDR transactions in securities that have a corporate action will be considered for automatic transformations and claims as and when appropriate (See Section 10).

Changes to the DBV Stock Movement Retrieve enquiry

The **DBV Stock Movement Retrieve (NDSR)**¹⁹ enquiry allows members to view the full list stock movements that relate to an Overnight DBV transaction using the interactive GUI.

With the introduction of the Term DBVs, this enquiry will be renamed more generically to **‘Stock Movement Retrieve’**. In addition, its scope will be extended to allow members to view the stock

¹⁹ This function was introduced by Euroclear UK & Ireland as part of its Overnight DBV service since the standard interactive GUI transaction retrieve function (ATXR) is only able to retrieve and display four stock movements.

movements related to Term DBV transactions (TDO, TDE, TDG, TDM and TDA) which could all potentially have up to 99 stock movements.

The direction of the stock movements shown by this enquiry is currently always from Collateral Giver to Collateral Taker. However, since the direction of the stock movements for Term DBV substitution transactions may be either way (see Section 8), the enquiry response will be enhanced to retrieve and display the following additional field:

- **Debit Party ID:** this field will identify the party being debited with the security in the transaction's stock movement.

Transaction status values

The **Term DBV Outbound (TDO)** transaction may undergo the following status changes:

Term DBV Outbound transactions	You	Counterparty	Transaction	Description
	Y	Y	F	Complete, no registration needed
	Y	Y	G	Actioned (settled), awaiting registration, (only applies to non ETT securities)
	Y	Y	H	Bad delivered (non ETT securities only)
	Y	Y	I	Complete, all lines of security registered
	Y	Y	J	Complete, one or more lines of security bad delivered (non ETT securities only)
	Z	Z	Z	Archived
Amendment of Return date/Interest Rate	Y	Y	F/I	Complete no registration/registered
	K	L	F/I	I input amendment to Return Date/Interest Rate
	L	K	F/I	Counterparty input amendment to Return Date/Interest Rate
	Y	Y	F/I	Complete no registration/registered
	Q	R	F/I	I input deletion to amendment
	R	Q	F/I	Counterparty input deletion to amendment
	Y	Y	F/I	Complete no registration/registered
Substitutions	Y	Y	F/I	Complete no registration/registered
	Y	Y	K	Substitution (TDE or TDM) required on a Term DBV transaction (transitory status)
	J	J	F/I	Substitution has settled (transitory status). Applies to all substitutions.
	Y	Y	F/I	Complete no registration/registered

Note: Although in general the YYF/YYI status values maybe regarded as final, in the case of Term DBVs, because of amendments and substitutions to the relating Term DBV there will be additional applicable transitory status values as shown above.

The TDO transaction will only be archived (i.e. given status ZZZ) when all of the associated Term DBV transactions have been archived.

Note: Term DBV transactions will be archived and weeded in the same way as Open/Term Repo transactions (i.e. archiving will occur 60 days after the settlement of the last Term DBV transaction, weeding will occur once all of the transactions have been successfully archived).

If the TDO transaction contains a mixture of securities – some of which need registration and some do not – the transaction will change to a status of ‘Complete, all registered’ (YYI) only once all the securities that need registration are successfully registered.

The **Term DBV Return (TDR)** transaction may undergo the following status changes:

Term DBV return transactions	You	Counterparty	Transaction	Description
	I	I	B	Not yet settlement date
	I	I	D	Delayed on settlement date
	I	I	E	Ready to action (settle)
	Y	Y	F	Complete, no registration needed
	Y	Y	G	Actioned (settled), awaiting registration, (only applies to non ETT securities)
	Y	Y	H	Bad delivered (non ETT securities only)
	Y	Y	I	Complete, registered
	Y	Y	J	Complete, bad delivered (non ETT securities only)
	Z	Z	Z	Archived
Split parent	S	S	C	Split (by me or by counterparty)
Sibling	I	I	B	As normal
Deletions	D	E	B	I delete the transaction before settlement date
	D	E	D	I delete a delayed transaction
	D	E	E	I delete a ready to action transaction
	E	D	B	Counterparty deletes transaction before settlement date
	E	D	D	Counterparty deletes a delayed transaction
	E	D	E	Counterparty deletes a ready to action transaction
	I	I	W	Centrally deleted by the system (transitory status)
	F	F	C	Deleted
Transformed	T	T	E	Transaction created by transformation and is ready for settlement (transitory status)
	T	T	D	Transaction created by transformation and is delayed on settlement date (transitory status)
	T	T	C	Transformed transaction and deleted
Amendment of return date	I	I	B	Not yet settlement date
	F	F	C	Deleted (existing TDR deleted for amend of Return Date)
	I	I	B	Not yet settlement date (new TDR created for amend of Return Date)
Substitutions	I	I	B	Not yet settlement date
	I	I	K	Generation of substitution attempted on a Term DBV transaction (transitory status)
	I	I	B	Not yet settlement date

All status changes for the TDO and TDR transactions will be reported to members using the standard File Changes mechanism, i.e. via QFCQ and ATSP messages.

Section 5: Term DBV interest accrual

Transferring accrued interest

The CREST system will automatically calculate and transfer accrued interest generated on Term DBVs (if any). The interest will be calculated on the basis of the cash consideration (and in the same currency).

Note: automatic calculation of interest will only take place where the Term DBV has consideration and a non-zero interest rate is specified on set up. Retrospective amendment of a zero rate interest will not lead to the automatic calculation of interest.

The accrued interest will be transferred from the Collateral Giver to the Collateral Taker (lender of cash) using the Term DBV interest payment (TDI) transaction.

The Term DBV will accrue interest for each calendar day from the day the outbound transaction (TDO) of the Term DBV settled to the calendar day before the Term DBV is scheduled to be returned (i.e. return date -1).

The interest will be calculated overnight on a daily basis and added to the consideration of the Term DBV interest payment transaction.

On reaching the intended settlement date (return date), the Term DBV will stop accruing interest at that point, regardless of whether or not the TDI actually settles. Any further interest payment relating to this period (where the TDI remains unsettled) will have to be resolved and dealt with by the counterparties themselves.

Calculating accrued interest

The CREST system will determine the daily²⁰ accrued interest on a Term DBV as shown below.

The calculation will use the day count convention for the currency involved. The interest rate²¹ used will be the rate that is applicable to the Term DBV on the day of the calculation.

- For GBP payments:
Consideration of the Term DBV x interest rate x 1/365 (this is an actual over 365 basis)
- For EUR and USD payments:
Consideration of the Term DBV x interest rate x 1/360 (this is an actual over 360 basis)

This calculation will take place daily as part of the overnight processing and the calculated amount will be added to the consideration of the Term DBV interest payment transaction.

For example, on Day 1, a Term DBV has been input (with an interest rate of 2%, and maturing in 6 days time) exchanging GBP 100 million of one specific stock against GBP 100 million of cash. Day 4 is a non-business day, and on Day 5 both parties to the transaction have amended the interest rate to 3% (See Section 6).

²⁰ Since these calculations in the CREST system only take place on a business day, if one or more of the consecutive days following the business day are non business days, then that overnight calculation will also account for these additional days.

²¹ The interest rate is an amendable attribute of a Term DBV (See Section 6).

The calculations for the accrued interest on this Term DBV will therefore be as follows:

Day	Interest Rate	Calculation	Calculated Amount	TDI Consideration
1	2%	GBP 100 million x 2% x (1/365)	GBP 5,479.45	GBP 5,479.45
2	2%	GBP 100 million x 2% x (1/365)	GBP 5,479.45	GBP 10,958.90
3	2%	GBP 100 million x 2% x (2/365)	GBP 10,958.90	GBP 21,917.80
4	2%	Non-business day	N/A	GBP 21,917.80
5	3%	GBP 100 million x 3% x (1/365)	GBP 8219.18	GBP 30,136.98

The final consideration value of the Term DBV interest payment transaction in this example will therefore be GBP 30,136.98.

Note: The CREST system will use the standard rounding convention when calculating the interest accrued, i.e. round down when the accrued interest is less than or equal to 4, round up when it is greater than or equal to 5.

Term DBV interest payment transaction (TDI)

The TDI transaction will be similar to the Overnight DBV interest payment transaction (DBI) and contains most of the standard fields for a transaction in the CREST system.

TDI transactions will be created:

- matched, with the intended settlement date set to the Term DBV return date;
- with a priority of 90; and
- in the same currency as the consideration of the Term DBV.

The TDI transaction will be assessed for settlement independently of any relating Term DBV return transactions.

The **Origin Transaction ID** (set to the Transaction ID of the TDO) and **Origin Transaction Ref** (set to the Transaction Reference of the TDO) fields of the TDI will be used to link the TDI back to the relating TDO transaction.

Members will be able to amend the following fields in TDI transactions using the existing **Transaction Amend (ATXA)** functionality.

- Transaction Reference
- Participant Note
- Shared Note
- Priority

Members will also be able to match-delete TDI transactions that have not settled via the existing **Transaction Delete (ATXD)** functionality.

Note: Both parties must input the deletion otherwise the transaction will continue to be put forward for settlement in the normal manner. Deleting the TDI transaction will cause the CREST system to set the interest rate attribute of the Term DBV to zero. Members will then not be able to update the interest rate. Once the TDI has been deleted, there will be no further central calculation of the accrued interest and it will not be possible for members to recreate the TDI.

The **Term DBV interest payment (TDI)** transaction may undergo the following status changes:

Term DBV interest payment transactions	You	Counterparty	Transaction	Description
	I	I	B	Not yet settlement date
	I	I	D	Delayed on settlement date
	I	I	E	Ready to action (settle)
	Y	Y	F	Complete, no registration needed
	Z	Z	Z	Archived
Deletions	D	E	B	I delete the transaction before settlement date
	D	E	D	I delete a delayed transaction
	D	E	E	I delete a ready to action transaction
	E	D	B	Counterparty deletes transaction before settlement date
	E	D	D	Counterparty deletes a delayed transaction
	E	D	E	Counterparty deletes a ready to action transaction
	I	I	W	Centrally deleted by the system (transitory status)
	F	F	C	Deleted

Section 6: Changing Term DBV attributes

Members will be permitted to change certain attributes of Term DBVs that have not reached the return date, as described below.

Amending the following attributes of a Term DBV will be possible via the existing **Repo Amendment Instruction (ARPA)** function, which already allows these attributes to be amended for Open/Term Repos:

- Return Date – to perform a roll-over or an early return of the Term DBV
- Interest Rate – to specify a new interest rate for the daily calculations of accrued interest
- Priority - to raise (or lower) the priority of all the return transactions of a Term DBV.

The functionality available to members for amendment of the above three attributes is described in this section.

For Term DBVs, members will also be able to amend the **DBV Value Sought** and **Consideration** attributes. This new functionality is described in Section 15.

For Term DBVs using the Bank of England haircut option, reference should also be made to Section 16 which describes additions to some of the functions (ARPQ/ARPL and ARRL) described in this section.

Collateral Amendment Instruction

With the introduction of Term DBV service, the '**Repo Amendment Instruction**':

- will be renamed to have the more generic name of, **Collateral Amendment Instruction**; and
- its scope will be extended to also cover Term DBVs.

The instruction will continue to use the same message (ARPA), however, some of the message fields will be renamed, as indicated below (renamed fields are indicated in bold):

- Transaction ID
- Transaction Reference
- **Next Return Date** (was 'Next Repo Return Date') – Amendments to the return date will be applied to all the Term DBV return transactions and to the Term DBV interest payment transaction (if any)
- Next Interest Rate
- Effective Date
- **Return Priority** (was 'Repo Priority') – This field may not be amended with either the Return Date or Interest Rate attributes.

Note: It will not be possible to amend the priority on Term DBV return transactions individually using the Transaction Amend function (ATXA).

The ARPA instruction is available via both file transfer and the interactive GUI.

Members will be able to amend the Term DBV attributes until 'DBV input disable' diary event (16:02 GMT) on the business day before Term DBV return date.

For Term DBVs, members will be able to update the **Return Date** and **Interest Rate** attributes independently of each other.

Note: For Open/Term Repos, the Interest Rate attribute can only be amended in combination with an amendment to the Return Date – this will continue to be the case.

Changes to the Return Date and Interest Rate attributes will need to be agreed on by both parties. Therefore, when the ARPA instruction is used to amend either of these two attributes, the instruction will need matching. Members may input an amendment to overwrite a previous amendment, as long as the original amendment has not been matched by the counterparty.

Changes to the **Priority** attribute only impact the priorities on the side of the amending party. Therefore, amendments to the Priority will not require the instruction to be matched.

Input of an ARPA amendment instruction which needs matching, will result in the associated TDO transaction being given an alleged participant transaction status of **K** or **L** (as appropriate)²². Following the input of the matching half of the amendment instruction, the participant transaction status of the TDO transaction will be returned to the original status before the amendment of the Return Date/Interest Rate, i.e. YYF/YYI etc. (See Section 4).

Input of amendment instructions that do not need matching (i.e. amendment of priority), will not result in a status change to the associated TDO transaction, as described above.

Successful matching of an amendment instruction involving a change to the Return Date will cause the central deletion of all the old TDRs related to the Term DBV and creation of the appropriate new TDRs with an intended settlement date of the **Next Return Date**. Additionally, where there is a TDI, the intended settlement date of that transaction will be updated to also reflect the new return date.

The status of the deleted TDR transactions will be updated to FFC. The new TDR transactions will be created with a status IIB/IIE (See Section 4).

For the purposes of reconciliation, the **Origin Transaction ID** and **Origin Transaction Ref** fields on the new TDR transactions will be populated with the Transaction ID/Transaction Reference of the original TDO. The new TDR transaction will also have the **Parent Transaction ID** field populated with the Transaction ID of the deleted TDR that it is replacing.

Early return functionality

Members will be able to use the ARPA functionality to return a Term DBV earlier than originally agreed by amending the **Next Return Date** field to a date earlier than the original return date entered. It will be possible for members to specify a **Next Return Date** equal to the current business day.

The CREST system will validate the **Next Return Date** field to ensure that the date entered is not earlier than the current business day.

Accrued interest calculation for roll-overs and early returns

For the current Open/Term Repos functionality, when the Return Date is amended to roll-over the repo, the accrued interest calculated for the new period²³ is based on the original repo consideration plus interest accrued to the stage of the roll-over. Thus, the interest accrued for rolled-over repos is compounded. However, for Term DBVs this will not be the case.

For Term DBVs, simple interest is calculated and accrued on a daily basis, based on the consideration of the Term DBV and interest rate applicable at the point of calculation. The interest accrual continues

²² Members will be able to view amendments that have been alleged against them using the 'Collateral Instruction List' (ARPQ) enquiry (described later in this section).

²³ For the purpose of the accrued interest calculations, the new period is defined as being from the Effective Date (of the amend instruction) up to and including the new Return Date.

on a daily basis until the day before the return date of the Term DBV. Thus, for an amendment where the Term DBV is rolled-over, the interest will just continue to be accrued without any compounding. For an amendment where the return date is brought forward for an early return, the Term DBV will stop accruing interest as soon as the day preceding the new return date has been reached.

Collateral Instruction List enquiry

Currently, members are able view the Open/Term Repos that they have in the CREST system by using the **Repo Instruction List** enquiry to retrieve the list of the related RPO transactions. The enquiry is available via both file transfer and the interactive GUI (**ARPQ/ARPL**).

Note: Details retrieved by the Repo Instruction List interactive GUI enquiry are displayed across two separate screens:

- **Repo Instruction List;** and
- **Repo Instruction Amend**

With the introduction of the Term DBV service, the Repo Instruction List enquiry/GUI screen will be renamed to have the more generic name of; **‘Collateral Instruction List’** and its scope extended to cover also Term DBVs, as described in this section. The enquiry will continue to use the same message codes as currently (i.e., ARPQ/ARPL).

The Collateral Instruction List screen will display a list showing the summary details of the retrieved data records²⁴. By double-clicking a record, a separate screen will open, currently called **‘Repo Instruction Amend’**. This screen shows further details of that record. With the introduction of Term DBVs, the ‘Repo Instruction Amend’ screen will be renamed to **‘Collateral Instruction Details’**.

CREST GUI screen updates

The new CREST GUI layout for the Collateral Instruction List screen is shown below:

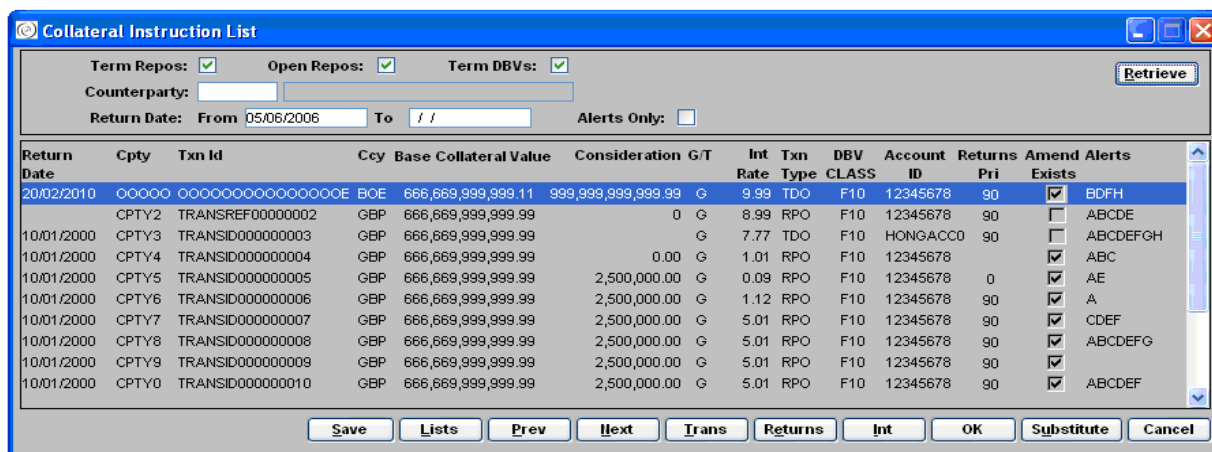

Note: The ‘Amend Exists’ column shown above is a screen-only field (i.e. it is not part of the response message) and is derived from the Effective Date, shown in the response message below. If the ‘Amend Exists’ check box is selected, it indicates that there is a pending amendment instruction against that Term DBV or Open/Term Repo.

Changes to the Collateral Instruction List screen will also include a navigational enhancement. The addition of a **Returns** and an **Interest Rate** button will allow members to view the relating return transactions and, where applicable, the interest payment transaction details.

²⁴ **Note:** The enquiry displays records of the outbound transactions (i.e. RPOs and TDOs).

The CREST GUI layout for the relating Collateral Instruction Details screen is shown below:

Collateral Instruction Details

Transaction Id: TRANSID0000000008 Txn Reference: TRANSREF0000000008

Counterparty Id: CPTY8 Cpty Short Name 08

Transaction Status: Not ready Party Transaction Status: Alleged to you

Int Settle Date: 01/01/2000

Currency: GBP Margin: 1.59 Apply BoE Haircut:

Alerts:

A: a stock substitution is needed
 B: Term DBV under-collateralised
 C: Term DBV over-collateralised
 D: Concentration limit breached
 E: a TDE txn has not yet settled

Base Collateral Value: 666,669,999,999.99
 Last Collateral Value: 776,669,999,999.99
 Difference: 110,000,000,000.00 over

Concentration Limit:

Returns Priority: 90

Current Values:
 Interest Rate: 5.01 Return Date: 10/01/2000

Next Values:
 Interest Rate: 6.02 Return Date: 11/01/2000 Effective Date: 02/02/2001

Buttons: Returns Delete Update Cancel

Selection criteria

The enhanced **Collateral Instruction List** enquiry will have the following new selection criteria²⁵:

- Open Repos
- Term Repos
- Term DBVs
- Alerts Only
- Counterparty
- Return Date fields

These criteria may be used individually or combined:

- The **Open Repos**, **Term Repos** and **Term DBVs** fields allow members to control the retrieved list of data to a specified collateral type. Members will be able to specify any combination of these three collateral types in their requests. However, at least one of the collateral types must be specified in the request.
- The **Alerts Only** field is applicable to Term DBVs only. It will allow members to restrict the retrieved list data to only those Term DBVs that have had an alert raised against them. Alerts are raised as a result of the overnight substitution and mark-to-market functionality (See Sections 8 and 9).
- The **Counterparty** field will allow members to restrict their retrieved list to data that only relates to collateral transactions with a specified counterparty.
- Members will be able to specify a date range in the **Return Date** fields (Selection Date From and Selection Date To) in order to further restrict their retrieved list data to collateral transactions (RPOs/TDOs) that have a return date which falls into the specified date range. By default, if members do not specify a value in the **Return Date** fields, members will receive list data relating to collateral transactions that have a return date greater than or equal to the current business day.

²⁵ The current selection criteria for the Repo Instruction List enquiry are: Counterparty, Intended Settlement Date, and Party Transaction Status.

Enquiry response

The **Collateral Instruction List** enquiry response message will be updated to incorporate the new fields as described below. Some existing fields will also be renamed.

The updated response message is shown below²⁶. Please note:

- new and renamed fields are indicated in bold;
- fields marked with a single asterisk are displayed only on the **Collateral Instruction List** screen;
- fields marked with double asterisks are displayed only on the **Collateral Instruction Details** screen; and
- fields without any asterisks are displayed on both GUI screens.

ARPL response message fields:

- **Base Collateral Value****:
 - For Term DBVs using DBV Margin, the Base Collateral Value will show the **Base Value Sought**²⁷ incremented by the applicable margin. For example, for a Term DBV with a Base Value Sought of GBP 100m and an applicable margin of 10%, the Base Collateral Value would show GBP 110m.
 - For Term DBVs using BoE Haircut (*or Term DBVs without any DBV Margin*), the Base Collateral Value will be the same as **Base Value Sought** (i.e. both fields will show the same amount).

Note: For Term DBVs, the Base Collateral Value will only change following an amendment of the Base Value Sought amount.

 - For Open/Term Repos, the Base Collateral Value will show the original market value of the collateral at the time that the Repo was input.
- **Last Collateral Value****:
 - For Term DBVs using DBV Margin, the Last Collateral Value will show the current market value of the Term DBV collateral (including the extra collateral that is needed to satisfy the applicable DBV Margin) based on the last reference prices available on the CREST system.
 - For Term DBVs using BoE Haircut, the Last Collateral Value will show the current market value of the Term DBV collateral (excluding the extra collateral needed to satisfy the applicable BoE Haircut) based on the last reference prices available on the CREST system.
 - For Open/Term Repos, the Last Collateral Value will show the current market value of the collateral in the Repo based on the last reference prices available on the CREST system.

The Last Collateral Value amount is updated on a daily basis as part of the CREST system overnight processing (after reference prices have been updated).

- **DBV Class*** - applies to Term DBVs only. Shows the code defining the set of security categories used to assemble the DBV. For Open/Term Repos this field will be set to blank
- **Account ID*** – identifies the member account relating to the collateral transaction (Term DBV or Open/Term Repo)

²⁶ Members should refer to existing Euroclear UK & Ireland publications for full description of the current fields applicable to the Repo Instruction List enquiry.

²⁷ Base Value Sought is the most recently agreed DBV Value Sought between the members for the Term DBV – see Section 15 for a definition.

- **Term DBV Interest Transaction ID** – applies to Term DBVs only. This is a unique ID generated by the CREST system for a Term DBV interest payment transaction. It does not appear on any screens; it is a technical field used for navigation purposes
- **DBV Concentration Limit**** - applies to Term DBVs only. Indicates whether or not a concentration limit applies to the Term DBV
- **Transaction Type*** – identifies the transaction type of the collateral transaction (i.e., TDO or RPO)
- **Apply BoE Haircut**** - will be selected to indicate that a Term DBV is valued using the Bank of England haircuts (See Section 16).
- **Mark to Market** (*this field is not shown on the GUI*) - it is included in the message for future use. Currently it is always set to Yes on Term DBV input.
- **TDO Alerts** – applies to Term DBVs only. The field displays a set of alert codes that are generated against a TDO transaction by the overnight substitutions and mark-to-market functionality (See Sections 8 and 9). Up to five alert codes may be generated concurrently by the CREST system. Each code is denoted by a single alphabetic character (described below) that indicates the type of alert raised against the Term DBV at the level of the TDO.

Note: For Certain TDO Alert codes (i.e. those arising as a result of an issue with one or more of the Term DBV constituents), additional information will be available through corresponding alerts that will be raised at the level of the TDR to identify the issue with the concerned collateral security (see ‘TDR Alerts’ below).

- **A:** one or more constituent security of the Term DBV requires substitution; the CREST system could not centrally generate a related TDE substitution to resolve the situation (e.g. because the Collateral Giver had insufficient replacement collateral or because more than 99 stock movements were required for the substitution).

The alert will not be raised if the system was able to successfully generate all the required TDE transactions. In the event of an unsettled TDE (identified by TDO alert code ‘E’), or where the TDE has been centrally cancelled (identified by TDO alert code ‘H’), members will be able to query the ‘Shared Note’ field of the relating TDE or the TDR Alert generated for the associated security, to identify the issue with the constituent security.

If TDO Alert code ‘A’ appears, there will be one or more associated TDR alerts.

- **B:** the Term DBV is under-collateralised and needs to be correctly balanced; the CREST system was unable to centrally generate the required TDM transaction to resolve the situation, either because the Collateral Giver had insufficient replacement collateral or because more than 99 stock movements were needed for the TDM transaction.

The alert will not appear if the system was able to successfully generate the TDM transaction²⁸. In the event of an unsettled TDM (identified by TDO alert code ‘F’), or where the TDM has been centrally cancelled (identified by TDO alert code ‘I’), members will be able to query the ‘Shared Note’ field of the relating TDM to determine whether or not the Term DBV is under-collateralised.

If there is no reference price available on the CREST system for one or more of the Term DBV constituents, the system will be unable to calculate the value of the Term DBV to determine whether or not the Term DBV is under-collateralised. In this case, the TDO Alert code ‘G’ (see below) appears instead.

TDO Alert code ‘B’ is not associated with TDR Alerts.

²⁸ The alert is not raised in such cases, as we would generally anticipate the TDM to settle and re-collateralise the Term DBV to be correctly balanced.

- **C:** the Term DBV is over-collateralised and needs to be correctly balanced; the CREST system was unable to generate the required TDM transaction or could only generate a TDM transaction to return some, but not all, of the required collateral to the Collateral Giver²⁹.

The alert will not appear if the system was able to successfully generate a ‘full’ TDM transaction³⁰. In the event of an unsettled TDM (identified by TDO alert code ‘F’), or where the TDM has been centrally cancelled (identified by TDO alert code ‘I’), members will be able to query the ‘Shared Note’ field of the relating TDM to determine whether or not the Term DBV is over-collateralised.

If there is no reference price available on the CREST system for one or more of the Term DBV constituents, the system will be unable to calculate the value of the Term DBV to determine whether or not the Term DBV over-collateralised. In this case, the TDO Alert code ‘G’ (see below) appears instead.)

TDO Alert code ‘C’ is not associated with TDR Alerts.

- **D:** one or more constituent security of the Term DBV is in breach of the concentration limit and needs to be correctly balanced; the CREST system was unable to centrally generate the required TDM transaction to resolve the situation, as the concerned security was not ‘Enabled’.

The alert will not appear if the system was able to successfully generate a TDM transaction to correctly balance all the constituent securities in breach of the concentration limit. In the event of an unsettled TDM, or if the TDM has been centrally cancelled, members will be able to query the ‘Shared Note’ field of the relating TDM, as described earlier. **Note:** A single TDM is generated to resolve both the under/over collateralisation and the concentration limit breach issues relating to a Term DBV (See Section 9). In the event that the TDM is generated to resolve the under/over collateralisation issue, but not the concentration limit issue, the TDO Alert ‘D’ will still appear.

TDO Alert code ‘D’ will have one or more associated TDR alerts.

- **E:** one or more TDE substitution transactions are centrally generated for the Term DBV, but at least one TDE has not yet settled.
- **F:** a TDM mark-to-market transaction is centrally generated for the Term DBV, but still remains unsettled.
- **G:** one or more constituent of the Term DBV has a security issue; the security may not be ‘Enabled’ or there may be no reference price available for a security.
TDO Alert code ‘G’ will have one or more associated TDR alerts.
- **H:** one or more of the centrally generated TDE transactions have been cancelled by the CREST system (i.e. those still remaining unsettled at the end of the related settlement window).
- **I:** the centrally generated TDM transaction has been cancelled by the CREST system (as it still remained unsettled at end of the settlement window).

- **Giver or Taker*** – identifies the role of the participant with respect to collateral security movement
- Transaction ID

²⁹ In the case of an over-collateralised Term DBV, a ‘partial’ TDM (i.e. a TDM that returns some of the required collateral, but not the full required quantity to rebalance an over-collateralised Term DBV) will arise as result of one or more of the Term DBV collateral securities not having an ‘Enabled’ status.

³⁰ The alert is not raised in such situations, as we would generally anticipate the ‘full’ TDM (i.e. a TDM that returns the full quantity required to rebalance an over-collateralised Term DBV) to settle and correctly re-balance the Term DBV.

- Transaction Reference**
- Party Transaction Status**
- Transaction Status**
- ISD**
- Effective Date**
- **Return Date** (was Repo Return Date)
- Next Return Date**
- Consideration*
- Currency Code
- **Collateral Margin**** (was Repo Margin)
- **Interest Rate** (was Repo Interest Rate)
- Next Interest Rate**
- Counterparty ID
- Counterparty Short Name**
- **Return Priority** (was Repo Return Priority)

Note:

The **File Transfer** enquiry response also returns the following additional fields, detailing the associated return transactions. However, these fields are not returned by the interactive GUI response. Members using the interactive GUI functionality can currently retrieve the equivalent information via a separate enquiry called **Repo Return List** (described later in this section).

- Debit Party Stock ID
- Credit Party Stock ID
- **Return Transaction ID** (was Repo Return Transaction ID) [*Repeating*]
- ISIN [*Repeating*]
- **TDR Alerts** [*Repeating*] – applies to Term DBVs only. This field displays a set of alert codes that is generated (in combination with the **TDO Alerts** – see above) by the overnight substitutions and mark-to-market functionality to identify issues found with the constituent securities of the Term DBV. Up to five alert codes may be generated concurrently by the CREST system. Each code is denoted by a single alphabetic character (described below) that indicates the type of alert raised against the Term DBV at the level of the TDR.

Note: Although the TDO Alerts do not always appear (i.e. where the system successfully creates the required TDE/TDM transaction to resolve the situation – see above), the TDR Alerts do, irrespective of whether or not the TDE/TDM are generated.

- **N**: the constituent security is no longer in the DBV Class of the Term DBV.
- **O**: the constituent security is no longer available for use with DBVs (i.e. DBV Allowed flag on security is set to ‘No’).
- **P**: the constituent security is due for maturity on the next business day.
- **Q**: the constituent security is due to expire on the next business day.
- **R**: the constituent security has an imminent corporate action (i.e. where the DBV Exclusion flag is set to ‘Yes’ and record date is next business day).

- **S**: the CREST system does not currently have a reference price for the constituent security.
- **T**: the constituent security does not have an ‘Enabled’ status.
- **U**: the constituent security is now on the exclusion list of the Collateral Taker.
- **V**: the constituent security is in breach of the Term DBV concentration limit.

TDR Alerts provide complimentary information to certain **TDO Alerts** that are raised (*some useful combinations are given below*):

- TDO Alerts code **A**: if a TDE transaction could not be generated, the TDR Alerts code: **N, O, P, Q, R** and **U** will apply, indicating the issue(s) found with the constituent security.
- TDO Alerts code **D**: if a TDM that is required to adjust the concentration limit of a TDR could not be generated, the TDR Alerts code **V** will apply.
- TDO Alerts code **E**: if TDE transactions have been generated but still remain unsettled, the TDR Alerts code **N, O, P, Q, R** and **U** will apply, indicating the issue(s) found with the constituent security.
- TDO Alerts code **F**: if a TDM transaction has been generated but still remains unsettled, the TDR Alerts code **V** will apply if the security of the TDR concerned is in breach of the concentration limit.
- TDO Alerts code **G**: if a TDE transaction could not be generated due to an issue with the constituent security, TDR Alerts code **S** and **T** will apply and will indicate why the security of the TDR concerned prevented the central generation.

- **Concentration** [*Repeating*] – shows the percentage value of a constituent security in a Term DBV or Open/Term Repo. For Term DBVs using DBV Margin, the Concentration percentage shows the market value of a constituent security as a percentage of the **Base Collateral Value** of the Term DBV. For Term DBVs using the BoE Haircut, the Concentration percentage will show the adjusted market value of a constituent security as a percentage of the **Base Value Sought**.
- Quantity [*Repeating*]
- **Return Consideration** (was Repo Return Consideration) [*Repeating*]
- **Return Transaction Status** (was Repo Return Transaction Status) [*Repeating*]

Collateral Return List enquiry

The existing **Repo Return List (ARRL)** enquiry, currently allows members to retrieve the list of repo return transactions (RPRs) that are associated with a specified Open/Term Repo (i.e. a RPO transaction). The enquiry is only available via the interactive GUI. For file transfer, the equivalent details are returned as part of the Collateral Instruction List enquiry (see above).

With the introduction of Term DBVs, the enquiry:

- will be renamed to have the more generic name of ‘**Collateral Return List**’; and
- its scope will be extended to also allow the retrieval of the Term DBV return transactions (TDRs) that are associated with a specified Term DBV (i.e. a TDO transaction). The enquiry will continue to use the same message code (ARRL).

The new CREST GUI layout for the Collateral Return List screen is shown below:

Transaction Id	Isin	Abbreviation	Quantity	Conc.	Consideration	Txn Status	Alerts
JCB1625911	GB1000666333	THMTREASURY2015001	16,520.	7.5	1,165,001.31	Not ready	
JCB1625912	GB1000666444	THMTREASURY2015002	27,652.	10.1	1,420,529.45	Not ready	V
JCB1625913	GB1000666555	THMTREASURY2015003	217,862.9	9.5	1,376,021.76	Not ready	
JCB1625914	GB1000666777	THMTREASURY2015004	85,521.	10.0	1,465,001.31	Not ready	O
JCB1625915	GB1000666888	THMTREASURY2015005	34,816,520.	9.2	1,262,886.08	Not ready	NOPRT
JCB1625916	GB1000666999	THMTREASURY2015006	6,953.	9.8	1,502,771.00	Not ready	
JCB1625917	GB1000667123	THMTREASURY2015007	216,250.	9.9	1,420,652.52	Not ready	
JCB1625918	GB1000667321	THMTREASURY2015008	3,898,519.	11.8	1,652,741.72	Not ready	UV
JCB1625919	GB1000667456	THMTREASURY2015009	16,902,857.58	9.8	1,841,762.33	Not ready	
JCB1625920	GB1000667654	THMTREASURY2015010	7,150,950.	9.9	1,022,776.17	Not ready	S

As a result of these changes, the updated response message will be as follows³¹ (new and renamed fields are indicated in bold):

- Transaction ID
- Transaction Reference
- Debit Party Stock ID
- Credit Party Stock ID
- Currency code
- **Return Transaction ID** (was Repo Return Transaction ID) [*Repeating*]
- ISIN [*Repeating*]
- **Security Abbreviation**
- **TDR Alerts** [*Repeating*] – see ARPQ enquiry (earlier in this section)
- **Concentration** [*Repeating*] – shows the percentage value of a constituent security in a Term DBV or Open/Term Repo (see definition given for Concentration field for the ARPL message earlier in this section)
- Quantity [*Repeating*]
- Consideration [*Repeating*]
- Transaction Status [*Repeating*]

³¹ Members should refer to existing Euroclear UK & Ireland publications for full description of the current fields applicable to the Repo Return List enquiry.

Section 7: Manual Adjustments of Term DBV Collateral

The CREST system will provide both manual and automatic substitution functionality to help members maintain the collateral of a Term DBV during the life of the arrangement.

This section describes the manual substitutions functionality that will be available to adjust the collateral held in a Term DBV.

For Term DBVs using the Bank of England haircut option, also refer to Section 16, which describes additions to some of the functionality described in this section.

Manual Substitutions

The manual substitution functionality will allow members to manage the securities that have been delivered out as collateral to a Term DBV. Members will be able to substitute out collateral securities from Term DBVs that have not reached the return date and replace them with other securities. Additionally, members will also be able to remove lines of securities or add additional lines of securities to the Term DBV.

Members will be able to carry out substitutions for Term DBVs using the existing **Repo Substitution Input (ASBN)** function that is used for Open/Term Repos. As a result of this change, the Repo Substitution Input function will be enhanced as described in this section. The function is available via both the file transfer and interactive GUI.

With the introduction of the Term DBV service, the use of the ASBN function (for both Open/Term Repos and Term DBVs) to input instructions will be restricted to the following times³²:

- **Early morning** (just after the end of the settlement window for TDE and TDM transactions) – this will be the first opportunity for members to input manual substitutions (via ASBN). Initially, this will be set to a two-hour window, but will be optimised over time depending on members usage of the function.
- **Late afternoon** (just prior to the start of the DBV settlement window) – this will be the last opportunity for members to input their manual substitutions.

Note:

1. The settlement of ASBN instructions for Term DBVs will be restricted to the above two windows. ASBN instructions input for Term DBVs in the early morning window will not be carried forward to the late afternoon window (i.e. unsettled instructions will be centrally deleted at the end of the window). Likewise, instructions that have been input and remain unsettled for the late afternoon window will also be centrally deleted.
2. There is no change to the settlement of ASBN instructions for Open/Term Repos; once input, the instructions will remain available for settlement until either they are settled or centrally deleted by the system (or deleted by the member).

The ASBN instruction only allows to add and/or delete one security to/from the Term DBV one at a time. Multiple instructions must be used if members want to substitute more than one security.

The ASBN instruction must be matched by both parties to the Term DBV.

Currently the input of an ASBN instruction results in the generation of the Repo Substitution (RPS) transaction. This will continue to be the case for ASBN instructions that are for substitutions on Open/Term Repos. For Term DBVs, however, the ASBN instruction will result in the generation of the new Term DBV Manual Substitution (TDS) transaction.

³² This restriction is imposed to ensure that manual substitution instructions input by members do not become invalidated as a result of the settlement activity associated with automatic substitutions that are generated by the system (i.e. TDE, TDM, and TDGs)

Collateral Management Manual Substitution Input (ASBN) Instruction

With Term DBVs, the ‘Repo Substitution Input’ enquiry will be renamed ‘Collateral Management Manual Substitution Input’.

As is currently the case, members will have to provide the following information in the ASBN instructions:

- **Transaction Reference** – the reference given to the transaction by the member.
- **Original Transaction Reference (optional)** - the Transaction Reference of the related TDO transaction for the Term DBV (if this is not specified, then the Original Transaction ID must be).
- **Origin Transaction ID (optional)** - the Transaction ID of the related TDO transaction for the Term DBV (if this is not specified, then the Original Transaction Reference must be).
- **Intended Settlement Date** (*Open/Term Repos only*) - the date on which the substitution must take place. Forward-dated substitutions will be permitted for Open/Term Repos only. **Note:** *This restriction is imposed to ensure that manual substitution instructions for Term DBVs do not become invalidated as a result of settlement activity from automatic substitutions that are associated with Term DBVs.*
- **ISIN (optional)** – the security to be removed from the Term DBV.
- **Quantity (optional)** - the security quantity to be removed from the Term DBV. If not specified, the full quantity of the security will be removed.
- **ISIN (optional)** – the security to be substituted into the Term DBV.
- **Quantity (optional)** – the quantity of the new security to be substituted into Term DBV. If not specified, the CREST system will centrally calculate the replacement quantity required to properly collateralise the Term DBV.
- **Priority**
- **Other standard fields** (e.g. Participant/Account details, Debit/Credit Party details)³³.

Substitutions for Term DBVs will require:

- the replacement collateral to come from the same account as was used with the TDO; and
- the returned collateral to go back to the same account as that of the TDO.

Therefore, where the ASBN instruction is for a substitution on a Term DBV, members will need to specify the same account details as were specified with the TDO.

Members will need to ensure that the replacement collateral (security to be substituted into the Term DBV) meets all the necessary eligibility criteria for a Term DBV (e.g. respects the DBV Class) – this will be validated by the CREST system³⁴.

The ASBN instruction will allow members to create the following types of substitution requests:

- **Full substitution** – replaces the entire value of one line of security with another of equivalent value.
- **Partial substitution** – replaces a partial value of one line of security with another of equivalent value.

³³ Members should refer to existing Euroclear UK & Ireland publications for the full set of fields and description for the ASBN instruction.

³⁴ **Note:** The ASBN instruction is also subject to the additional changes as described in Section 16 - Valuation of DBVs using Bank of England Haircuts.

- **Collateral injection**³⁵ – transfers in an additional security to the Term DBV (this may be in a security of a line already used or a new line) without any removal. In this situation, the limit of 99 lines of security (on input) will not apply.
- **Collateral removal**³⁶ – transfers out an existing security from the Term DBV without any replacement.

The ‘**Quantity**’ fields of the ASBN instruction are optional and do not need to be specified by the members. If no value is given the CREST system will centrally determine the value of the **Quantity** fields as follows:

- If the **quantity to be removed** has not been specified, the quantity determined by the system will be such that the entire line of security will be removed.
- If the **quantity to be added** has not been specified, the quantity determined by the system will be such that it will maintain the collateral value of the overall Term DBV (taking into account any quantity to be removed and using the latest CREST reference prices).

Note: Values specified for the **Quantity** field on the ASBN instruction will not be validated by the CREST system to ensure that the specified value:

- maintains the overall collateral value of a Term DBV; or
- does not lead to a breach of the concentration limit (if any) for the relating securities.

With manual substitutions, members will be responsible for ensuring that their ASBN instructions maintain the collateral value of a Term DBV correctly. In any case, during the overnight processing of the same day as the settlement of the TDS transaction, if the CREST system finds that the Term DBV is under- or over-collateralised, the mark-to-market process will seek to generate a mark-to-market adjustment transaction (for settlement next business day) to readjust the Term DBV to ensure that its collateral value is correctly maintained.

Note: the consideration (if any) of a Term DBV is apportioned across all the Term DBV return transactions (See Section 2). Generally, the consideration of a TDR will be a close reflection of the value of the collateral of that TDR³⁷. When any central adjustments are made to a Term DBV (i.e. TDRs relating to the Term DBV), the consideration of the TDR is centrally maintained by the automatic substitution and mark-to-market functionality to ensure that it continues to closely reflect the value of the collateral of the TDR.

When a manual substitution occurs (which can move stock but not cash), the consideration of the TDR may be left disproportionate to the value of the collateral of the TDR (since no automatic adjustments will take place to the TDR consideration (see example later in the section). Furthermore, where the manual substitution removes all of an existing line of security, the relating TDR will be deleted (including the consideration on that TDR); the net effect on the Term DBV being that the sum of the considerations on all the remaining TDRs will no longer equal the base consideration.

Manual substitutions may therefore, in general, leave members with an intraday exposure, which will need to be dealt with manually if not desirable. In any case, this exposure should be removed by the next overnight mark-to-market. The mark-to-market process will seek to realign the collateral of the Term DBV to the level of the base collateral value (DBV value sought + any margin) and then reapportion the base consideration across all the realigned TDRs (See Section 9).

³⁵ This allows the collateral of a term DBV to be increased, e.g. if Term DBV is under-collateralised.

³⁶ This allows the collateral of a term DBV to be decreased, e.g. if Term DBV is over-collateralised.

³⁷ Normally (i.e. where the **consideration** and **DBV value sought** of a Term DBV are equal) the consideration of the TDR would equal the value of the TDR collateral minus the margin.

Note: Whenever there is a change to the collateral security system price(s), the CREST system will reapportion the original consideration across all related TDRs of the Term DBV. This is independent of the reapportionment that takes place as a result of the automatic substitution/mark-to-market functionality (See Section 9).

For Term DBVs, it will not be possible to input manual substitution instructions (ASBN) once the return date of the Term DBV has been reached. The CREST system will therefore reject input of manual substitutions on and after the return date of the Term DBV.

Term DBV Manual Substitution Transaction (TDS)

The TDS transaction generated as a result of the ASBN instruction will be similar to the RPS transaction. It will be a delivery versus delivery (DvD) transaction (with a maximum of two stock movements) and will not contain any cash movements.

The TDS transaction will transfer the required amounts of security in and/or out of the Term DBV and will cause the deletion and/or creation of Term DBV return (TDR) transactions where required.

Settlement of TDS transactions

TDS transaction will be settled in two distinct windows as described earlier (see ‘Manual Substitutions’ at the beginning of this section).

Upon settlement of the TDS transaction, the CREST system will centrally manage the impact on the TDRs associated with the Term DBV, as follows.

For each security movement specified on the TDS:

- If the security movement removes all of an existing constituent security, the associated TDR will be deleted (no new TDR created in this instance).
- If the security movement increases/decreases an existing constituent security, the associated TDR will be deleted and a new TDR will be created with the revised quantity and the same consideration as that was on the original TDR. All other details for the new TDR will remain the same.
- If the security movement is for a security that is not already a constituent of the Term DBV, a new TDR will be created with a zero consideration.

Note: Transaction status changes for these TDRs (created/deleted as a result of the TDS settlement) will be reported to members as reporting of any other transaction status change (See Section 4 for the TDR status values).

The following examples are provided below:

- full substitution; and
- partial substitution.

Example of a Full substitution

A Term DBV is set up for a value sought of GBP 1,650 (including a 10% margin), and a consideration of GBP 1,500 (Concentration Limit is not applicable).

TDR transactions exist for the Term DBV as follows:

Transaction ID	Security	Price	Quantity	Value	Consideration
TDR1	Security A	0.50	880	440	400
TDR2	Security B	1	220	220	200
TDR3	Security C	2	55	110	100
TDR4	Security D	3	110	330	300
TDR5	Security E	2	275	550	500

Note: At this stage the consideration of the TDR is a close reflection of the value of the underlying security (exclusive of the margin).

After a period, Security A is due to mature.

The price of Security A has risen from GBP 0.50 to GBP 0.80. The price of Security B has risen from GBP 1 to GBP 1.05. There has been no change in price for any of the other collateral securities.

The TDRs for the Term DBV will be as follows (assuming that, overnight, the consideration has been reapportioned across the TDRs, but the adjustment TDM transaction generated by mark-to-market did not settle):

Transaction ID	Security	Price	Quantity	Value	Consideration
TDR1	Security A	0.80	880	704	549
TDR2	Security B	1.05	220	231	180
TDR3	Security C	2	55	110	86
TDR4	Security D	3	110	330	257
TDR5	Security E	2	275	550	428

Note: Because the TDM transaction failed to settle, there is now a disparity between the consideration of the TDR and value of the underlying security.

To replace the maturing security (Security A), a matched **ASBN** instruction requesting the substitution of Security A by Security F is received by the CREST system. Neither of the two 'Quantity' fields ('Quantity to be removed' or 'Quantity to be added') are specified in the instruction.

Security F has a price of GBP 0.55.

The CREST system will calculate the amount of Security F needed to replace Security A using the following method:

The total value of the Term DBV is currently $880(0.8) + 220(1.05) + 55(2) + 110(3) + 275(2) = \text{GBP } 1,925$.

Removing Security A: $1925 - 704 = 1221$

Therefore, the required value of Security F to balance the Term DBV (with the original value sought, using the latest prices) is $1650 - 1221 = \text{GBP } 429$.

continued on next page...

The CREST system will calculate:

- the quantity of Security F to be added as: $\text{GBP } 429 / 0.55$ (price of Security F) = 780
- the quantity of Security A to be removed as: 880 (full line of stock).

To maintain the original total value of the Term DBV at GBP 1,650, the CREST system will generate a TDS transaction which transfers in **780 units of Security F** and removes **880 units of Security A**.

Note: *If the original value of collateral in the Term DBV is maintained, even though a security line is removed, the CREST system will not add any of the replacement security into the Term DBV (unless a specific quantity was specified on the substitution instruction).*

Upon settlement of this TDS, the CREST system will centrally delete the Term DBV return transaction relating to Security A and create a new Term DBV return transaction for Security F (with a zero consideration). The TDRs for the Term DBV will now be as follows:

Transaction ID	Security	Price	Quantity	Value	Consideration
TDR2	Security B	1.05	220	231	180
TDR3	Security C	2	55	110	86
TDR4	Security D	3	110	330	257
TDR5	Security E	2	225	550	428
TDR6	Security F	0.55	780	429	0

Note: *the total consideration (GBP 951) across all the TDRs is now less than the base consideration that was specified for the Term DBV (i.e. GBP 1,500). This will remain out of step until the original consideration is reapportioned again by the automated overnight functionality.*

Example of a Partial substitution

Suppose that, following settlement of the above TDS, the CREST system now receives a matched ASBN instruction requesting to return 125 units of Security E and insert 125 of Security C.

Note: the insertion quantity could have been left blank to let the system calculate it.

Upon settlement of the TDS, the CREST system will centrally delete and recreate the TDRs relating to Securities C and E (the new TDRs will be created with the original consideration values). The TDRs for the Term DBV will therefore be as follows:

Transaction ID	Security	Price	Quantity	Value	Consideration
TDR2	Security B	1.05	220	231	180
TDR7	Security C	2	180	360	86
TDR4	Security D	3	110	330	257
TDR8	Security E	2	150	300	428
TDR6	Security F	0.55	780	429	0

Note: A disparity has arisen between the consideration of the TDR and the value of the underlying security.

During the overnight processing, based on the prices available to the CREST system, the consideration of TDRs will be reapportioned automatically by mark-to-market as follows (assume no price change).

Transaction ID	Security	Price	Quantity	Value	Consideration
TDR2	Security B	1.05	220	231	210
TDR7	Security C	2	180	360	327
TDR4	Security D	3	110	330	300
TDR8	Security E	2	150	300	273
TDR6	Security F	0.55	780	429	390

Settlement of the TDS transaction will result in a transitory participant transaction status change to the associated TDO transaction. The TDO transaction will be given a participant transaction status of 'J' to indicate that a substitution has occurred within the Term DBV.

Amendment and deletion of TDS substitutions

Members will be able to amend (using ATXA) the following set of fields for a TDS transaction:

- Transaction Reference
- Participant Note
- Shared Note
- Priority

Members that want to change their input for any other data will need to delete and re-input the substitution instruction before settlement.

A matched TDS transaction must be deleted by both parties to prevent the substitution from settling. Members can delete the transaction using the Transaction Delete function (ATXD) instruction. This instruction must identify the substitution that requires deletion by stating either:

- the transaction reference given to the substitution by the member; or

- the transaction ID generated for the substitution by the CREST system.

Deletions can be carried out before the settlement of the associated substitution transaction.

It will not be possible to split TDS transactions.

TDS transaction status values

The TDS transaction may undergo the following status changes:

Substitution transaction	You	Counterparty	Transaction	Description
	B	A	A	My input unmatched
	A	B	A	Counterparty input unmatched (alleged to me)
	I	I	E	Ready to action (settle)
	Y	Y	F	Complete, no registration needed
	Y	Y	G	Actioned (settled), awaiting registration, (only applies to non ETT securities)
	Y	Y	H	Bad delivered (non ETT securities only)
	Y	Y	I	Complete, registered
	Y	Y	J	Complete, bad delivered (non ETT securities only)
	Z	Z	Z	Archived
Deletions	D	E	E	I delete a ready transaction
	E	D	E	Counterparty deletes a ready transaction
	I	I	W	Centrally Deleted (transitory status)
	F	F	C	Deleted

In the situation where the TDS transaction contains a mixture of two securities, one of which needs registration and the other does not, the TDS will gain a status of “Complete, Registered” (YYI) only once the securities that need registration are successfully registered.

All status changes for the TDS transaction will be reported to members using the standard File Changes mechanism, i.e. via QFCQ and ATSP messages.

Section 8: Automatic Substitutions

The CREST system will provide both manual and automatic substitution functionality to help members maintain the collateral of a Term DBV during the life of the arrangement.

This section describes the automatic substitutions functionality that will be available for the Term DBV service.

For Term DBVs using the Bank of England haircut option, also refer to Section 16 which describes additions to some of the functionality described in this section.

Overview

The Term DBV service will have an automatic substitution functionality which will allow the CREST system (on behalf of the member) to centrally manage the collateral in a Term DBV. There will be two forms of automatic substitutions:

- **Intraday substitutions** – if the Collateral Giver encounters settlement failure on market transactions as a result of a deliverable security being out on Term DBV collateral, the CREST system will centrally generate an intraday Term DBV substitution transaction to attempt to recall the required collateral and allocate one or more security lines of equivalent value to replace it. This substitution transaction is new for the Term DBV service and will be known as **Term DBV Giver Recall (TDG)** substitution.
- **Overnight substitutions** – during the life of a Term DBV, existing collateral may need to be centrally excluded or may become ineligible to continue being held within the Term DBV³⁸. In such cases, the CREST system will centrally generate an overnight Term DBV substitution transaction (for settlement next business day) to recall the affected collateral and allocate one or more security lines of equivalent value to replace it. This substitution transaction is new for the Term DBV service and will be known as **Term DBV Eligibility (TDE)** substitution.

Note: Automatic substitutions may result in more lines of security being added to a Term DBV than being removed. In this case, the limit of 99 lines of security (on Term DBV input) will not apply.

Term DBV Giver Recall (TDG) substitutions

To aid settlement of failing transactions, the CREST system will centrally generate (on an intraday basis) Term DBV Giver Recall (TDG) substitution transactions to switch out the required security from a Term DBV and replace it with equivalent alternate collateral (in one or more lines of security).

The TDG substitution will be a delivery versus delivery (DvD) transaction (with a maximum of 99 stock movements): one stock movement to the Collateral Giver and zero³⁹ or more stock movements to the Collateral Taker. The TDG transaction will have the same set of fields as the manual substitution (TDS) transaction.

The process for the generation of TDG substitutions will be initiated via a new daily diary event. This diary event will be timed to allow failed transactions a sufficient window of opportunity to settle by other means before the system generates TDG substitutions to aid their settlement.

³⁸ Collateral may become ineligible as a result of a change to the security (e.g. change of security category), or it may become centrally excluded, for example, as a result of an imminent mandatory corporate action against the collateral security (such as a Reorganisation event).

³⁹ In the exceptional case where the value of the collateral being recalled is zero (e.g. where bid price is zero), there is no replacement collateral involved. In this case the TDG transaction would be one-to-zero.

There will also be two new daily diary events (expected to run just before end of ‘Equity Settlement’ and before end of ‘Gilt Settlement’) to stop the generation of the TDG substitutions in equities and gilts respectively.

Criteria for TDG substitution generation

Central generation of Term DBV Giver Recall (TDG) substitutions will be considered for transactions that fail to settle and meet the following conditions:

- The transaction is one of the following types: DEL, OAT, SLO, STW, TTE, USE, XDL, DBR, RPR, SLR, TDR.
- The transaction involves a security movement and the reason for settlement failure is insufficient securities.
- Settlement failure of the transaction occurs on:
 - the intended settlement date (or the first business day that follows, if the intended settlement date was not a business day); or
 - the first business day after the intended settlement date (where the transaction was unable to settle on the intended settlement date).
- The stock debit party to the failed transaction is a Collateral Giver to one or more Term DBVs (involving the security of the failed transaction) which utilises the same member account as that of the failed transaction.

Note: Term DBVs which are due to mature/settle on the same day as the day of the settlement failure will not be considered for the purpose of this check.
- The shortfall⁴⁰ quantity of the failed transaction is adequately covered by the total quantity of the security out on Term DBV collateral. For example, if there is a settlement shortfall of 100 units (i.e. after accounting for any quantity present on Available and SCR balance) and there are two Term DBVs that together only have a total of 90 units of the failed security, no substitution will be generated.
- The stock debit party (i.e. Collateral Giver) has sufficient quantity of alternate, eligible replacement collateral (in a single line or a parcel of different securities) available in the same member account as was used with the Term DBV.

Note:

1. For settlement efficiency, transactions that fail to settle will be considered for the TDG substitution functionality only on the first two settlement days. If a transaction still remains unsettled after two days, it is unlikely that any further generation of TDG substitutions will aid in its settlement. Failed transactions that are older than two days will therefore not generate TDGs; members will need to find alternate means to settle such transactions.
2. There will be no particular order in which failed transactions will be processed by the system.

The intraday automatic substitution functionality is based on the following guiding principles:

- The shortfall of the security required for the settlement of the failed transaction may be retrieved from more than one Term DBV.

⁴⁰ If the failed transaction is for the delivery of 150 units of a security, but the participant has 20 units of the security in their Available balance and a further 30 units out on SCR, then the participant is deemed to have a settlement shortfall of 100 units (for the purpose of recall of Term DBV collateral).

- The total retrieval from one or more Term DBVs will be for the entire amount of the shortfall (on an all or nothing basis).
- One or more TDG substitution transactions may be generated to retrieve the shortfall of the required collateral security. There will be one TDG transaction for each Term DBV from which collateral must be recalled.
- Generation of the TDG substitutions will only be attempted if the Collateral Taker to a Term DBV has some quantity of the required security in their Available balance (and where suitable replacement collateral is available with the Collateral Giver (See Selection of replacement collateral later in this section).

Selection of collateral to be ‘recalled’

For each failed transaction that requires the generation of a TDG substitution (i.e. as some stock is out on Term DBV), the CREST system will centrally identify the relevant list of Term DBVs in which the failed security is out on collateral. It will then select one or more of these Term DBVs for substitutions to make up the required shortfall quantity.

There are two distinct lists of Term DBVs that must be considered for substitution:

1. Immediate Term DBVs

These are Term DBVs where:

- the Collateral Giver is the same participant as the stock debit party of the failed transaction;
- the security of the failed transaction is a collateral security to the Term DBV;
- the member account of the failed transaction is the same account as that being utilised by the Term DBV; and
- the return date of the Term DBV has not been reached.

2. Onward Delivered Term DBVs

These are Term DBVs that have arisen as a result of the Collateral Taker (to the above Term DBVs) onward delivering the required security to other party/parties (via Term DBVs) as well as those Term DBVs that then arise as a result of these parties further onward delivering the security to other parties, and so on (See diagram in the example that follows later in this section).

The list making up the set of Immediate Term DBVs is known. However, the list of the Onward Delivered Term DBVs must be determined by traversing down the chain of Term DBVs that may have been created as a result of the onward delivery of the collateral security.

Since the chains formed by the Onward Delivered Term DBVs is of unknown quantity and magnitude, for efficiency of performance, the CREST system will limit the depth to which it explores the chains to locate the required collateral. This will be a configurable limit that will be optimised over time.

The algorithm used to retrieve the shortfall of the required collateral security is illustrated in the example on the next page. It may be helpful for you to refer to the diagram in that example when reading the following description.

To locate and retrieve the shortfall of the required security, the system will initially scan a subset of the list of Immediate Term DBVs, e.g. the first 4.

Note: the value of 4 has been used for illustration purposes only, the actual number used will be a configured number that will be optimised over time.

If the shortfall of the required security can be met by the scan of this initial subset, then these are the Term DBVs that will be used for the retrieval.

If the shortfall is not met, the system will scan across any chains of Onward Delivered Term DBVs that may exist for this subset of Immediate Term DBVs.

Note: As mentioned above, the system will only scan to a depth of a defined number of Term DBVs across the chain of Onward Delivered Term DBVs.

If the system is able to meet the shortfall from the Onward Delivered Term DBVs in combination with whatever was available from the subset of the Immediate Term DBVs, then these are the Term DBVs that will be used for the retrieval.

Should the shortfall not be met from the above scans, the system will continue to work down the list of the remaining Immediate Term DBVs and across any further chains of Onward Delivered Term DBVs that may exist, until either the shortfall is fully met or the list of Term DBVs is exhausted.

Example: Approach to a recall of required collateral

Suppose that Party A is a stock debit party to a failed transaction meeting the criteria required for TDG substitution generation.

The diagram below shows that Party A has delivered the required security as collateral in Term DBVs to Parties B, C, D, E, and F. The diagram also shows two chains of Term DBV transactions that have arisen as a result of Parties B and D (Collateral Takers to the immediate Term DBVs) onward delivering the required security.

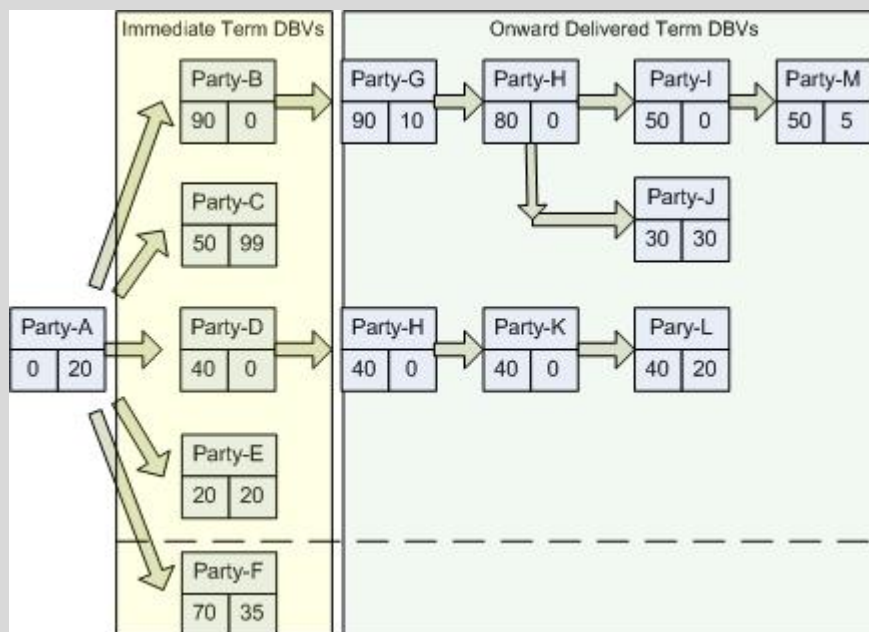

Two numbers are shown below each Party in the diagram:

- The first number (i.e. box on left) denotes the quantity of collateral received (of required security) by the party as a result of the Term DBV.
- The second number denotes the quantity of the required security that remains with the party in their Available balance.

For Party G, **90/10** means that Party G received **90** in a Term DBV but only **10** still remains in their Available balance.

Party A has 20 units of the required security in their account but does not have enough to meet the delivery requirement of the failed transaction since the security has been used as collateral in a number of Term DBVs.

continued on next page ...

Scan of the Immediate Term DBVs

To locate the required collateral, the system will begin by scanning a subset of the Immediate Term DBVs (assume for this example the subset is made up of 4 Term DBVs). So in this instance, it would be the Term DBVs to Parties B, C, D, and E:

- The system will determine the quantity of the required security that is available across the subset of Term DBVs. In this example, there are **70** (0+50+0+20) units of the required security.
Note: the system will take the lesser of the Term DBV quantity and the Available balance quantity, e.g. Party C (since only the collateral that is the result of a Term DBV can be recalled from a party).
- The system will traverse this list of Term DBVs in descending sequence of the Available balance quantity held in the parties account (in this example, sequence C, E, B, D):
 - if the shortfall quantity is less than or equal to **50**, then recall of the required security will take place from the Term DBV to Party C (in this case, a single TDG substitution transaction would be generated);
 - if the shortfall quantity is greater than **50** and less than or equal to **70**, then recall of the required security will take place from Term DBV to Party C and Term DBV to Party E (in this case, two TDG transactions would be generated).

If the shortfall is greater than **70**, having exhausted the subset of Immediate Term DBVs, the system will scan any Onward Delivered Term DBV chains that may exist for the subset. In this example, the chains initiated by Parties B and D.

Scan of the Onward Delivered Term DBVs

The system will start with the first chain (i.e. that initiated by the Term DBV to Party B). A scan will be made across all the Term DBVs originating from Party B (assume for this example that system will scan to a depth of up to 3 Term DBVs). In this case, a total of **40** units may be recalled (**10** from Party G and **30** from Party J).

Note: the **5** units available from Party M are not considered, as that Term DBV falls outside the depth of the scan):

- if the shortfall quantity is greater than **70** and less than or equal to **80**, then recall of the required security will take place from the Term DBVs to Parties C, E and G (in this case, 4 TDG transactions would be generated).
Note: 2 TDGs would be required to recall from Party G);
- if the shortfall quantity is greater than **80** and less than or equal to **110**, then recall of the required security will take place from the Term DBVs to Parties C, E, G and J (in this case, 8 TDG transactions would be generated).
Note: 4 TDGs would be required to recall from Party J).

If the shortfall quantity is greater than **110**, the system will scan the next chain of Onward Delivered Term DBVs (i.e. that initiated by the Term DBV to Party D). A scan will be made across all the Term DBVs originating from Party D. In this example, only **20** units may be recalled (i.e. from Party L):

- if the shortfall quantity is greater than **110** and less than or equal to **130**, then recall of the required quantity will take place from the Term DBVs to Parties C, E, G, J and L (in this case, 12 TDG transactions would be generated.)
Note: 4 TDGs would be required to recall from Party L.

If the shortfall quantity is greater than **130**, the system must now continue to work down the list of the remaining Immediate Term DBVs. In this example, a scan will be made of the Term DBV to Party F and **35** units may be recalled from Party F:

- if the shortfall quantity is greater than **130** and less than or equal to **165**, then recall of the required quantity will take place from the Term DBVs to Parties C, E, G, J, L and F (in this case, 13 TDG transactions would be generated).
Note: 1 TDG would be required to recall from Party F.

If the shortfall quantity is greater than **165**, the system will abort the search for the required collateral as the list of Term DBVs has now been exhausted.

Selection of replacement collateral

For each TDG transaction that must be generated, the allocation of the replacement collateral (from the Collateral Giver) will be as follows:

- If the collateral is being recalled from an Immediate Term DBV:
 - selection of the replacement collateral from the Collateral Giver’s member account must follow the standard DBV allocation rules;
 - the replacement collateral must be in the same member account as was used with the Term DBV;
 - the replacement collateral selected must not include the line of security which is being recalled from the Term DBV;
 - the replacement collateral selected must respect the concentration limit (if one was specified for the Term DBV); and
 - the replacement collateral selected must be such that the total number of different lines of security movements required for the TDG is not more than 99.
- If the collateral is being recalled from an Onward Delivered Term DBV (so that a chain of substitutions is required) selection of the replacement collateral from the Collateral Giver’s member account will follow the same criteria as above (for the Immediate Term DBVs), but subject to the following constraints:
 - the replacement collateral must only be in a single line of security, and that security must be acceptable to all Collateral Takers in the chain; and
 - if a Term DBV (one or more) in the chain has specified a concentration limit, the single line of replacement collateral selected must be one that is not already used as collateral in any of the Term DBVs in the chain.

Central Generation of TDG Transactions

If the CREST system is unable to identify replacement collateral from the Collateral Giver’s account, there will be no central generation of the TDG substitution transaction.

A TDG substitution transaction that is successfully created will:

- specify the ISIN and Quantity of the security being recalled;
- specify the ISIN and Quantity of each selected line of the replacement collateral;
- use the same member accounts as were used for the Term DBV; and
- be created with a transaction priority of 75.

When a TDG transaction is created, the counterparties to the Term DBV will be notified by transaction status file change.

Settlement of TDG transactions

We anticipate that TDG transactions will be considered for settlement from late morning (around 11:00 GMT) to the end of the normal settlement period.

Settlement of a TDG transaction will result in the deletion and/or creation of a Term DBV return (TDR) transaction for each collateral security movement specified in the TDG:

- If the security movement is for a security that is not already a constituent of the Term DBV, a TDR transaction will be created.
- If the security movement removes all of an existing constituent security, the related TDR will be deleted.
- If the security movement increases or decreases the quantity of an existing constituent security, the related TDR transaction will be deleted and a new one created with the revised quantity.

If the Term DBV relating to the settled TDG has a consideration, the apportioned consideration on TDRs that are deleted will be re-apportioned across the new TDRs that will be created.

Example: Re-apportioning of the consideration

A Term DBV is set up for a value sought of GBP 1,100 (including a 10% margin) and a consideration of GBP 1,000 (concentration limit is not set). TDR transactions exist for the Term DBV as follows:

Transaction ID	Security	Price	Quantity	Value	Consideration
TDR1	Security A	1	550	550	500
TDR2	Security B	2	110	220	200
TDR3	Security C	2	165	330	300

A TDG transaction recalls 300 units of Security A and substitutes it with 90 units of Security B and 120 units of Security D. The settlement of this TDG transaction will mean a consideration of 700 (500 + 200) must be re-apportioned, since the settlement of the TDG will require deletion of TDR1 and TDR2.

After settlement of the TDG, the TDRs for the Term DBV will be as follows with the consideration re-apportioned as shown:

Transaction ID	Security	Price	Quantity	Value	Re-apportioned consideration
TDR4	Security A	1	250	250	227
TDR5	Security B	2	200	400	364
TDR3	Security C	2	165	330	300
TDR6	Security D	1	120	120	109

Transaction status changes for the TDRs that are created and deleted on the back of settled TDGs will be reported to members in the same way as any other transaction status change (See Section 4 for the TDR status values).

The successful settlement of a TDG substitution transaction will return the Term DBV collateral back to the Collateral Giver's account. This collateral will then be available to settle⁴¹ the failed transaction which gave rise to the TDG substitution.

Example

Suppose a participant has account A as its trading account, and account B as its DBV account. The participant has input a DEL from account A, and a Term DBV from account B. *The security of the DEL is a collateral security on the Term DBV.*

The participant's DEL transaction has failed settlement (from account A).

In this case, the Intraday Automatic Substitution functionality will not generate a TDG transaction since there are no Term DBV transactions from account A.

The participant must submit an OAT transaction from their DBV account (account B), to their trading account (account A). Either the OAT will settle, in which case the earlier DEL will now settle, or the OAT will not settle, in which case:

- the Automatic Substitution functionality will generate a TDG substitution to return the required collateral security to account B;
- the OAT will settle, moving the security from account B to account A; or
- once the OAT settles, the DEL can finally settle (assuming there were no other pending transactions contending for the same collateral security).

A transaction status change for a settled TDG transaction will be reported to members as per any other transaction status change.

Settlement of the TDG transaction will result in a transitory participant transaction status change to the associated TDO transaction. The TDO transaction will be given a participant transaction status of J to indicate that a substitution has occurred within the Term DBV.

Note: after the generation of the TDG, the transaction status of the relating failed transaction will have no impact on the TDG; i.e. regardless of whether, for example, the failed transaction becomes settled or deleted (by the member), the TDG will continue to progress through settlement.

Those TDG transactions that still remain unsettled at the end of day will be centrally deleted by the CREST system. Deleting the TDG will allow the system to try and settle the failed transaction again (the following morning) on the basis of other settlement activity of the participant taking place. If the failed transaction still remains unsettled, the system will generate another TDG when the diary event for TDG substitutions is run (as described above)⁴². The transaction status change of the deleted TDG will be reported to members as per any other transaction status change.

Note: The CREST system will attempt to settle a group of TDGs together (i.e. all at the same time) if that group of TDGs was generated to retrieve the settlement shortfall for a single failed transaction. However, this may not always be possible, in which case the TDGs will settle on an individual basis.

⁴¹ If the Collateral Giver has other transactions pending for settlement with equal or higher priority and which are also contending for the same collateral, then there is no guarantee as to which transaction will actually end up settling.

⁴² **Note:** The failed transactions will give rise to TDG substitutions only for the first two settlement days (See earlier description at the beginning of the section).

Amend and Delete the TDG transactions

Members will be able to use the existing Transaction Amend functionality (ATXA) to update the following set of fields in a TDG transaction:

- Transaction Reference
- Participant Note
- Shared Note
- Priority

Members will also be able to match-delete unsettled auto generated TDG transactions using the standard Transaction Delete function (ATXD) instruction. This instruction must identify the TDG substitution that requires deletion by stating either the transaction ID generated by the CREST system or the transaction reference given (via ATXA) to the substitution by the member.

Note: Both parties must input the deletion, otherwise the transaction will continue to be put forward for settlement in the normal manner.

It will not be possible to split TDG transactions.

TDG transaction status values

The TDG transaction may undergo the following status changes.

Term DBV Giver Recall transactions	You	Counterparty	Transaction	Description
	I	I	E	Ready to action (settle)
	I	I	D	Delayed on settlement date
	Y	Y	F	Complete, no registration needed
	Y	Y	G	Actioned (settled), awaiting registration, (only applies to non ETT securities)
	Y	Y	H	Bad delivered (non ETT securities only)
	Y	Y	I	Complete, registered
	Y	Y	J	Complete, bad delivered (non ETT securities only)
	Z	Z	Z	Archived
Deletions	D	E	D	I delete a delayed transaction
	D	E	E	I delete a ready to action transaction
	E	D	D	Counterparty deletes a delayed transaction
	E	D	E	Counterparty deletes a ready to action transaction
	I	I	W	Centrally Deleted (transitory status)
	F	F	C	Deleted

If the TDG transaction contains a mixture of securities, some of which require registration and some which do not, the TDG will gain a status of 'Complete, Registered' (YYI) only once all the securities that require registration are successfully registered.

All status changes for the TDG transaction will be reported to members using the existing file changes mechanism, i.e. via QFCQ and ATSP (Transaction Status Change Response) messages.

Term DBV Eligibility (TDE) Substitutions

Collateral in a Term DBV will be maintained centrally by the CREST system by generating Term DBV Eligibility (TDE) substitution transactions.

During the overnight processing at the end of each business day, the CREST system will monitor the constituents of Term DBVs until one business day before the return date of the Term DBV. For each Term DBV where the system identifies a constituent as having become ineligible or where the constituent security is in need of central exclusion (see definitions below) the system will centrally generate TDE substitutions to switch out the identified constituent security and replace it with equivalent alternate collateral (in one or more lines of security). A separate TDE transaction will be generated for each constituent of the Term DBV that must be substituted out.

The TDE transaction will be a stock only transaction (with a maximum of 99 stock movements): one stock movement to the Collateral Giver and one or more stock movements to the Collateral Taker.

Identification of ineligible collateral

A Term DBV constituent security will be identified as having become ‘ineligible’ to be continued to be held within a Term DBV, when that security is found to meet one or more of the following conditions:

- The Security Category of the constituent has changed, and the security no longer falls within the DBV Class specified for the Term DBV.
- The constituent security has been amended and is no longer useable for DBVs (i.e. the DBV Allowed attribute of the security has been updated to indicate ‘No’).
- The constituent security has been added to the list of securities that the Collateral Taker is not prepared to accept in a DBV (i.e. added to the Collateral Taker’s list of exclusions).

Identification of collateral to be centrally excluded

A Term DBV constituent security will be identified as needing to be centrally excluded from a Term DBV, when that security is found to meet one or more of the following conditions (that impacts the collateral):

- The constituent security is due to expire (end) on the next business day.
- The constituent security has a mandatory corporate action with a DBV Exclusion attribute set to ‘Yes’ and where the current day is the business day before the record date of the corporate action⁴³.

Each constituent security to a Term DBV identified as either having become ineligible or to be centrally excluded will be flagged to members via alert codes that will be created against the related TDR transaction. The alert codes will indicate the issue found with the underlying constituent security (See Section 6 for the defined set of alert codes). Additionally, for each such constituent security identified, the system will need to generate a separate TDE substitution to replace that collateral.

Members will be able to view the details of the alerts raised via the Collateral Return List (ARPQ / ARRL) functionality (See Section 6).

⁴³ The objective of this exclusion is to avoid the need for complex corporate action processing such as claims and transformations.

Identification of replacement collateral

For each TDE substitution that must be generated, the CREST system must identify suitable replacement collateral (from the Collateral Giver) as follows:

- The selection of the replacement collateral from the Collateral Giver’s member account must follow the standard DBV allocation rules.
- The replacement collateral must be in the same member account as was used with the Term DBV.
- The replacement collateral selected must not include the line of security which is being recalled from the Term DBV.
- The replacement collateral selected must not include securities that have a corporate action with a DBV Exclusion attribute set to ‘Yes’ and a record date of the next business day.
- The replacement collateral selected must respect the concentration limit (if one was specified for the Term DBV).
- The replacement collateral selected must be such that the total number of different lines of security movements required for the TDE is not more than 99.

If the CREST system is unable to identify replacement collateral from the Collateral Giver’s account, there will be no central generation of the TDE substitution transaction.

Central generation of TDE transactions

TDE transactions will be centrally generated for Term DBVs if all the following conditions are met:

- A constituent security of the Term DBV is identified either as being ineligible or as needing to be centrally excluded.
- The Collateral Giver has suitable replacement collateral for the substitution.
- The collateral to be recalled has a security status of ‘Enabled’ and a bid price for the security is available on the CREST system.
- The Collateral Taker is or is not currently in possession of the constituent security that is to be replaced.

Note: The system will generate a TDE substitution transaction even when the Collateral Taker no longer has the security in their relating member account, on the assumption that the Collateral Taker may acquire the required security on the following day during the settlement window.

Successful creation of one or more TDE transactions for the Term DBV will result in an alert being raised against the TDO transaction (alert code **E**). This alert will inform the members that TDE transactions have been generated (one or more) and are awaiting settlement.

Note: Upon successful settlement of all the TDEs, this alert will be removed (as explained further below).

The creation of the TDE will correspond with a transitory status change to the associated TDO and TDR transactions. The TDO and TDR transactions will be given a transaction status of **K** to indicate that a substitution is required for the Term DBV.

Note: The creation of the TDE will also be reported via transaction status changes as per normal transaction processing (See **Transaction Status Values** later in this section).

Note: the automatic overnight substitution functionality will not be able to generate TDE transactions under the following conditions:

- a) If the Collateral Giver has insufficient replacement collateral in the required member account or if the replacement collateral selected results in more than 99 lines of security movements for the TDE.

It is our understanding that current market practice for certain members is to ‘empty their box’ i.e. to have zero positions in their accounts overnight. However, with the introduction of the Term DBV service to avoid the problem of the system not being able to generate TDE substitutions, members should ensure that they have sufficient overnight collateral in their member accounts related to Term DBVs.

- b) If the constituent security to be substituted out has already expired.

This situation may arise either as a result of the system failing to generate the required TDE substitution or as a result of the generated TDE failing to settle. In this case, during the overnight process of the day after the end date of the security, the standard CREST system security processing functionality will centrally ‘Complete’ the associated TDR transaction. The Term DBV will then be rebalanced by the mark-to-market functionality during the same overnight process.

- c) If there is no bid price available to the system for the constituent security that is to be substituted out.
- d) If the constituent security to be substituted out does not have an ‘Enabled’ status.

Failing to generate a required TDE transaction (one or more) for a Term DBV will result in an alert being raised against the TDO transaction (alert code **A**)⁴⁴. This alert will inform members that central generation of one or more of the required TDE transactions was not possible. Additionally, if there is a security issue with the collateral (i.e. cases **c** and **d** above), a separate alert will also be raised against the TDO (alert code **G**)⁴⁵.

Failing to generate the TDE transaction will correspond with a transitory status change to the associated TDO and TDR transactions. The TDO and TDR transactions will be given a transaction status of **K** to indicate that a substitution is required for the Term DBV.

Note: The combination of the alerts and file change mechanism will allow members to identify Term DBVs where it has not been possible to centrally generate TDE substitutions, and then take any corrective action in line with their processing intentions.

A TDE transaction that is successfully created will:

- be created for settlement next business day;
- specify the ISIN and Quantity of the security being recalled;
- specify the ISIN and Quantity of each selected line of the replacement collateral;
- use the same member accounts as were used for the Term DBV;
- be created with a transaction priority of 92;
- have the **Origin Transaction ID** and **Origin Transaction Ref** fields populated with the Transaction ID/Transaction Reference of the original TDO; and
- have the Shared Note field contain CREST system generated text giving the reason for the creation of the TDE substitution.

⁴⁴ **Note:** More than one alert code may be generated against a TDO; for example, alert codes **EA** against a TDO will indicate that one or more required TDEs have been generated but have yet to settle and one or more of the required TDEs for the Term DBV could not be generated.

⁴⁵ The system will also generate corresponding alert codes against the related TDR(s) to indicate the security issue found with the collateral security (See Section 6).

Settlement of TDE transactions

TDE transactions will be generated overnight for settlement next business day (for early morning settlement).

Settlement of a TDE transaction will result in deleting and/or creating a Term DBV return (TDR) transaction for each collateral security movement specified in the TDE, as follows:

- If the security movement is for a security that is not already a constituent of the Term DBV, a TDR transaction will be created.
- If the security movement removes all of an existing constituent security, the related TDR will be deleted.
- If the security movement increases the quantity of an existing constituent security, the related TDR transaction will be deleted and a new one created with the revised quantity.

If the Term DBV relating to the settled TDE has a consideration, the apportioned consideration on TDRs that are deleted will be re-apportioned across the new TDRs that will be created (This re-apportionment processing is identical to the re-apportionment carried out for settlement of TDGs. See the example provided in the TDG section for further information).

Transaction status changes for the TDRs that are created and deleted on the back of the settled TDEs will be reported to members as per any other transaction status change (See Section 4 for the TDR status values).

Successful settlement of each TDE transaction will result in a reset (i.e. removal) of the relating alert that was raised against the associated TDR transaction. Upon successful settlement of **all** TDE transactions for a Term DBV, the alert raised against the TDO transaction will also be reset.

Note: If TDEs remain unsettled, the alerts on the associated TDO and TDR transaction will not be reset and will remain present until the overnight process is run at the end of day.

Central deletion of TDE transactions

A new diary event will run to stop the settlement of TDE transactions. Those TDE transactions that still remain unsettled at the end of the settlement window will be centrally deleted by the CREST system. This new diary event will be timed to run before the existing 'Stop DVP Equity Settlement' diary event, to provide a sufficient window clear of any TDE settlement. This will allow members to make alternative arrangements (such as manual substitutions) before close of business, should they choose to do so.

The central deletion of one or more of the TDE transactions will result in an alert being raised against the associated TDO transaction (alert code **H**). This alert will inform members that centrally generated TDEs for the Term DBV have been deleted. Transaction status changes related to the deleted TDEs will be reported to members as per any other transaction status change.

Generated alerts and associated file changes

The following table summarises the alerts (see Section 6 for definitions) and file changes associated with the TDE substitution functionality described in this section:

Action	TDO	TDR	TDE
Identification of constituents to be substituted out from a Term DBV.	-	Alert (various) - indicates issue(s) found with the constituent security	-
Constituent security does not have bid price or a status that is Enabled.	Alert (G) - indicates security issue. Additionally, where there is a need to substitute out the concerned security, there will also be an alert code (A) – to indicate that the TDE could not be created. There will also be an appropriate alert raised against the TDR (as describe above).	Alert (S, T) – indicates the type of issue found with the security	-
Issue with replacement collateral [Fails to create TDE]	- (see Fails to create TDE)	-	-
TDE: Created	Alert (E) - indicates TDE generated but not yet settled. File Change (K)	File Change (K)	File Change (E)
TDE: Fail to create	Alert (A) - indicates required TDE could not be created. File Change (K)	File Change (K)	-
TDE: Settled	Reset alert code (E) – upon settlement of all TDEs.	Reset relating alert for the associated TDR	File Change (F/I)
TDE: Centrally Deleted	Alert (H) - indicates TDE centrally deleted at end of settlement.	-	File Change (W)

Note: All alerts are reset and revalidated as part of the daily overnight processing.

Amend and delete the TDE transactions

Members will be able to use the existing Transaction Amend functionality (ATXA) to update the following set of fields in a TDE transaction:

- Transaction Reference
- Participant Note
- Shared Note

Note: Members will not be able to amend the priority of the TDE transactions as TDEs will be centrally created with a high priority of 92.

Members will also be able to match-delete unsettled TDE transactions using the standard Transaction Delete function (ATXD) instruction. This instruction must identify the TDE substitution that requires deletion by stating either the transaction ID generated by the CREST system or the transaction reference given (via ATXA) to the substitution by the member.

Note: Both parties must input the deletion, otherwise the transaction will continue to be put forward for settlement in the normal manner.

It will not be possible to split TDE transactions.

TDE transaction status values

The TDE transaction may undergo the following status changes.

Term DBV Eligibility transactions	You	Counterparty	Transaction	Description
	I	I	E	Ready to action (settle)
	I	I	D	Delayed on settlement date
	Y	Y	F	Complete, no registration needed
	Y	Y	G	Actioned (settled), awaiting registration, (only applies to non ETT securities)
	Y	Y	H	Bad delivered (non ETT securities only)
	Y	Y	I	Complete, registered
	Y	Y	J	Complete, bad delivered (non ETT securities only)
	Z	Z	Z	Archived
Deletions	D	E	D	I delete a delayed transaction
	D	E	E	I delete a ready to action transaction
	E	D	D	Counterparty deletes a delayed transaction
	E	D	E	Counterparty deletes a ready to action transaction
	I	I	W	Centrally Deleted (transitory status)
	F	F	C	Deleted

If the TDE transaction contains a mixture of securities, some of which requires registration and some do not, the TDE will gain a status of 'Complete, Registered' (YYI) only when all the securities that require registration are successfully registered.

All status changes for the TDE transaction will be reported to the members using the standard file changes mechanism, i.e. via QFCQ and ATSP messages.

Section 9: Mark-to-market adjustments

With the introduction of the Term DBV service, a mark-to-market functionality will be provided to centrally align the daily value of the collateral in Term DBVs as described in this section.

For Term DBVs using the Bank of England haircut option, also refer to Section 16, which describes additions to some of the functionality described in this section.

Overview of the mark-to-market functionality

During the overnight processing at the end of each business day after the reference prices have been updated, the CREST system will centrally recalculate the value each Term DBV to determine:

- if the value of the Term DBV is over-collateralised or under-collateralised in comparison to the value originally sought plus any margin⁴⁶;
- if any of the constituent securities are in breach of the concentration limit (if the concentration limit is applicable to the Term DBV); or
- if the original Term DBV consideration needs to be re-apportioned across all the related TDRs (to reflect the relative collateral value of each respective constituent).

Where the Term DBV has become over or under-collateralised, or where a constituent security is found to be in breach of the concentration limit⁴⁷ (where applicable) the mark-to-market process will centrally generate a mark-to-market collateral adjustment transaction (for settlement next morning) to increase or decrease the collateral within a Term DBV, as appropriate. This adjustment transaction is new for the Term DBV service and will be known as a ‘Term DBV Mark-to-Market’ (TDM) transaction.

The mark-to-market process will also ensure that the original Term DBV consideration is correctly apportioned across all the related TDRs in proportion to the percentage of collateral held in the respective TDRs.

The Term DBV Mark-to-Market (TDM) transaction will be a stock only transaction (with a maximum of 99 stock movements). It may have one or more stock movements to the Collateral Giver and/or one or more stock movements to the Collateral Taker. The TDM will seek to correct the composition of the Term DBV via a single transaction on an all-or-nothing basis.

Mark-to-market threshold

To limit the mark-to-market activity to significant changes in value, a threshold will be applied to align the value of the collateral in the Term DBV against the original value sought, plus the margin. This threshold will only be applied to the calculated collateral value while determining whether the Term DBV is over or under-collateralised. The threshold is not applied to check on the concentration limit, meaning that where a concentration limit is applicable, if any given constituent exceeds the 10% limit (even by a penny), it will give rise to a TDM transaction being generated.

The threshold will be defined at the level of the DBV Class and currency. The current proposal (following discussions with the market) is that the value of the mark-to-market threshold should be set to GBP 1, EUR 1 or USD 1 in all cases.

⁴⁶ The alignment will take into consideration the mark-to-market threshold applicable to the DBV Class of the Term DBV (see ‘Mark - to-market threshold’ later in this section).

⁴⁷ **Note:** Where a concentration limit applies, the mark-to-market process may lead to the generation of a TDM transaction, even if the Term DBV is properly collateralised.

Generation of Mark-to-Market Transactions (TDMs)

The mark-to-market process will be scheduled to run in the CREST overnight processing after all other processes that could potentially alter the set of constituents in a Term DBV either in shape, content or value. It allows the mark-to-market process to take account of all possible changes before generating the adjustments required to properly re-collateralise the Term DBV. This means that the mark-to-market processing will run after the automated transformations, the automated TDE substitutions generation and the security expiry processes.

The mark-to-market process will work on the principal that the Term DBV must be properly collateralised, taking account of any centrally generated TDE substitutions. Therefore, for the purpose of calculating the value of a Term DBV, the mark-to-market process **will work on the assumption** that any TDE substitutions generated will be successfully settled the following morning⁴⁸.

During the overnight process at the end of each business day, until the business day before the return date of the Term DBV has been reached, the mark-to-market process will:

- Calculate the current total value of the Term DBV collateral, taking into consideration any overnight TDE substitutions that may have been generated for the Term DBV.
- If concentration limit is applicable for the Term DBV, the value of each constituent security will be calculated to see if it breaches the limit (i.e. to see if the current market value of a constituent security is more than 10% of DBV Value Sought plus any applicable DBV Margin; for Term DBVs using BoE Haircut – see Section 16). If the constituent security is in breach of the limit, the process will calculate the quantity of that security to be returned to the Collateral Giver so that the security is no longer in breach of the concentration limit.
- If the calculated value of the Term DBV collateral (after taking account of any quantity to be removed for breach of concentration limit, if appropriate) is such that the Term DBV is not correctly balanced:
 - if the Term DBV is **over-collateralised** after taking account of the applicable mark-to-market threshold, the system will attempt the return of one or more of the constituent securities back to the Collateral Giver, as follows:
 - a) the full amount of securities required to correctly re-balance the Term DBV (i.e. to a value equal to the amount of the over-collateralisation) if all the constituent securities are ‘Enabled’. **Note:** The System will try to re-balance the Term DBV such that it is within the applicable **Threshold** value; or
 - b) the maximum amount possible using the ‘Enabled’ securities, in the event that there are insufficient ‘Enabled’ securities (i.e. as a result of one or more of the constituent securities not being ‘Enabled’)
 - if the Term DBV is **under-collateralised** after taking account of the applicable mark-to-market threshold, the system will attempt to select additional collateral (single or a parcel of different securities) to a value equal to the amount of the under-collateralisation from the Collateral Giver⁴⁹ to be delivered to the Collateral Taker

Note: In the case of under-collateralisation, the system will attempt to re-balance the Term DBV to within the **Tolerance** value (See Section 2)
- Generate a **single** TDM transaction containing all these stock movements (i.e. adjustments to re-balance the Term DBV and where appropriate the concentration limit), as described above.

⁴⁸ **Note:** the Term DBV may be left over- or under-collateralised if the generated TDE substitutions fail to settle. However, since the mark-to-market process runs on a daily basis, the process will attempt to centrally correct the collateralisation when it is invoked on the following day. In any case, since members will be made aware of these settlement failures they will be able to take the necessary manual actions needed to rectify the situation should they wish to do so.

⁴⁹ The mark-to-market process will utilise the standard DBV stock allocation process to select the required collateral.

TDM transactions will be successfully generated where the need has been determined and where the following conditions are satisfied for the Term DBV⁵⁰:

- No constituent in the Term DBV has a reference price equal to zero.
- The total number of different lines of security movements required in the TDM is not more than 99.
- In the case of a breach of concentration limit for a specific constituent, as long as that constituent security is enabled for settlement. If the Term DBV is under/over collateralised, a TDM will still be generated (subject to meeting all the required conditions), but will not include the movement to fix the breach of concentration limit of the security that is not 'Enabled'.

Note: The TDM will be generated to correct the concentration limit even if the Term DBV is left improperly collateralised (as a result of insufficient replacement collateral).

- In the case of under-collateralisation, the Collateral Giver has the required additional collateral such that it satisfies all the following criteria:
 - the required collateral follows the standard DBV allocation rules;
 - the required collateral is in the same member account as was used with the Term DBV;
 - the required quantity has not already been allocated to another overnight mark-to-market or a TDE substitution transaction;
 - the collateral selected does not include securities that have a corporate action with a DBV Exclusion attribute set to 'Yes' and a record date of the next business day;
 - the collateral selected respects the concentration limit (where applicable).
- In the case of over-collateralisation, the following conditions must be met:
 - there is at least one 'Enabled' constituent security that can be returned to the Collateral Giver;
 - the Collateral Taker has or does not have the constituent security that is to be returned in their relating member account.

Note: The CREST system will centrally generate a TDM transaction even when the Collateral Taker no longer has the security in its account, on the assumption that the Collateral Taker may acquire the required security on the following day, during the settlement window.

The mark-to-market functionality will not be able to generate a TDM if:

- any constituent in the Term DBV has a reference price equal to zero⁵¹;
- the number of security movements required to be generated would exceed 99;
- in the case of under-collateralisation, the Collateral Giver does not have sufficient eligible⁵² collateral which is 'Enabled' for settlement and can be used to re-collateralise the Term DBV;
- in the case of over-collateralisation, there is insufficient 'Enabled' securities that can be removed from the Term DBV; and
- if the concentration limit is breached, the security for the respective constituent is not 'Enabled'.

⁵⁰ The collateral of the Term DBV used for purpose of these checks will not include any potential changes that may occur as a result of TDEs that may have also been generated for the Term DBV.

⁵¹ A reference price of zero of any constituents undermines the ability to calculate the value of the Term DBV as a whole.

⁵² Various conditions can determine if a security can be included in a DBV or not, as defined in the preceding paragraph.

Failure to generate the required TDM transaction or, in the case of over-collateralisation, where it was only possible to generate a ‘partial’ TDM transaction, the system will raise an alert against the TDO and a corresponding file change record (see ‘Generated alerts and associated file changes’ at the end of this section).

Members will be able to view such alert details using the Collateral Instruction List functionality (currently called Repo Instruction List – see Section 6). This mechanism will allow members to identify Term DBVs where it has not been possible to generate TDM transactions and take any corrective action in line with their processing intentions.

A TDM transaction that is successfully created will:

- specify the ISIN and quantity of each constituent security being returned to the Collateral Giver;
- specify the ISIN and Quantity of each additional collateral security being added to the Term DBV;
- use the same member accounts as were used for the Term DBV;
- be created with a transaction priority of 91;
- have the shared note field contain CREST system generated text, giving the reason for the creation of the TDM transaction;
- have the **Origin Transaction ID** and **Origin Transaction Ref** fields populated with the Transaction ID/Transaction Reference of the original TDO; and
- give rise to the creation of a file change to each counterparty and the setting of an alert flag at the TDO level to indicate that a mark-to-market instruction is yet to settle.

Settlement of TDM transactions

TDM transactions will be generated overnight for settlement the next business day. The settlement of the TDM transaction will occur on an all-or-nothing basis.

Settlement of a TDM transaction will result in creating and/or deleting a Term DBV return (TDR) transaction for each collateral security movement specified in the TDM and the generation of a file change for each of the counterparties. A TDR transaction will be:

- created if the security movement is for a collateral security that is being added to the Term DBV and that is not already a constituent of the Term DBV;
- deleted if the security movement removes all of an existing constituent security; and
- deleted and recreated (with the new quantity) if the security movement increases or decreases the quantity of an existing constituent.

If the Term DBV relating to the settled TDM has a consideration, this amount will be re-apportioned across all the TDR transactions,⁵³ so that the consideration on each of the TDRs is a fair reflection of the constituent’s value.

For reorganisation events that have an outturn of cash only proceeds, on transformation date (which will typically be the same as the record date), the corporate action processing for Term DBVs will transform any unsettled TDRs (where the underlying collateral is subject to these events and the TDR

⁵³ That is, the Term DBV TDR transaction set following to the settlement of the TDM transaction.

has a consideration) into a set of cash only DEL transactions (See Section 10). These cash only DEL transactions are generated by the transformation process to represent:

- the cash consideration element of the original TDR (DEL1); and
- the security element of the original TDR transformed in to the cash outturn (DEL2).

Following the above transformation processing, the mark-to-market process will generate a TDM to:

- seek to re-collateralise the Term DBV to account for the security quantity transformed out; and
- re-apportion the original Term DBV cash consideration amount across all TDRs related to the respective Term DBV.

Upon settlement of such a TDM – since the mark-to-market process re-apportions the original consideration across all the TDRs relating to a Term DBV – the first cash only DEL transaction (DEL1) is superfluous and thus will be centrally deleted on settlement of the relating TDM transaction. A file change will be generated for the deleted DEL transaction.

A new diary event (which will be the same as the one used to stop settlement of the TDEs) will be used to stop the settlement of TDM transactions. Those TDM transactions that remain unsettled at the end of the settlement window will be:

- centrally deleted by the CREST system;
- notified to each counterparty via file change on the TDM; and
- highlighted against the relating TDO transaction through an alert flag (see ‘Generated alerts and associated file changes’ at the end of this section). Members will be able to view these alert details through the Collateral Instruction List functionality (currently called Repo Instruction List – see Section 6).

The new diary event will be scheduled to run before the existing ‘Stop DVP Equity Settlement’ diary event, to provide a sufficient window clear of any TDM/TDE settlement activity. This will allow members to make alternative arrangements (e.g. manual substitutions) before the close of business, should they choose to do so.

Re-apportionment of consideration

The update of the security reference prices during the overnight process will impact the collateral value of TDRs where the price of the relating security has changed. Term DBVs that have not reached their return date will therefore be assessed by the mark-to-market process, to re-apportion the original consideration of the Term DBV across all its relating TDRs, so that the consideration on each TDR is a fair reflection of the actual relative value of the collateral in that TDR in comparison to the total Term DBV collateral value.

For example, if the value of the collateral on a TDR is 10% of the total value of the Term DBV collateral, the mark-to-market process will adjust the consideration on that TDR to be 10% of the total Term DBV consideration.

No new transaction will be created for this purpose and no specific notifications will be issued.

Consideration will be re-apportioned in this way (i.e. the consideration on the TDRs will be updated), even if no TDM transaction is generated.

Amend and delete the TDM transactions

Members will be able to amend (using ATXA) the following set of fields for a TDM transaction:

- Transaction Reference
- Participant Note
- Shared Note

Note: Members will not be able to amend the priority of the TDM transactions because they will be centrally created with a high priority of 91.

Members will also be able to match-delete unsettled auto-generated TDM transactions using the standard Transaction Delete function (ATXD) instruction. This instruction must identify the TDM that requires deletion by stating either the transaction ID generated by the CREST system or the transaction reference given (via ATXA) to the transaction by the member.

Note: Both parties must input the deletion otherwise the transaction will continue to be put forward for settlement in the normal manner.

It will not be possible to split TDM transactions.

TDM transaction status values

The TDM transaction may undergo the following status changes.

Term DBV mark-to-market transactions	You	Counterparty	Transaction	Description
	I	I	E	Ready to action (settle)
	I	I	D	Delayed on settlement date
	Y	Y	F	Complete, no registration needed
	Y	Y	G	Actioned (settled), awaiting registration, (only applies to non ETT securities)
	Y	Y	H	Bad delivered (non ETT securities only)
	Y	Y	I	Complete, registered
	Y	Y	J	Complete, bad delivered (non ETT securities only)
	Z	Z	Z	Archived
Deletions	D	E	D	I delete a delayed transaction
	D	E	E	I delete a ready to action transaction
	E	D	D	Counterparty deletes a delayed transaction
	E	D	E	Counterparty deletes a ready to action transaction
	I	I	W	Centrally Deleted (transitory status)
	F	F	C	Deleted

If the TDM transaction contains a mixture of securities, some of which require registration and some which do not, the TDM will gain a status of ‘Complete, Registered’ (YYI) only once all the securities that require registration are successfully registered.

All status changes for the TDM transaction will be reported to members using the standard file changes mechanism, i.e. via QFCQ and ATSP messages.

Generated alerts and associated file changes

The following table summarises the alerts and file changes associated with the TDM substitution functionality described in this section

Action	TDO	TDR	TDM	Comments
Term DBV is under-collateralised and needs to be correctly balanced.	Alert (B) - indicates that the Term DBV is under-collateralised and that a TDM could not be created. File Change (K)	-	-	
Term DBV is over-collateralised and needs to be correctly balanced.	Alert (C) - indicates that the Term DBV is over-collateralised; the system has been unable to create the required TDM, or it was only possible to create a partial TDM. File Change (K)	-	-	
A constituent security of the Term DBV is in breach of the concentration limit and needs to be correctly balanced.	Alert (D) – indicates the concentration limit is breached for one or more of the Term DBV constituent securities, but the system was unable to resolve the situation. File Change (K)	Alert (V) - indicates TDO concentration limited breached. File Change (K)	-	
TDM: Created.	Alert (F) - indicates TDM generated, but not settled.	-	File Change (E)	Will get reset upon settlement of TDM or upon central deletion of the failed TDM.
TDM: Settled.	File Change (K)	-	File Change (F/I)	Reset respective flags at TDO and TDR level.
TDM: Centrally Deleted	Alert (I) - indicates TDM centrally deleted at end of settlement.	-	File Change (W)	

Note: All alerts are reset and revalidated as part of the daily overnight processing.

Section 10: Corporate action processing

Term DBV return (TDR) transactions will be subject to corporate action processing, given that it is possible that TDRs will remain open (i.e. unsettled) during the course of corporate actions and, in particular, on the record date of such events.

Generic Corporate Action Types

For ease of reference, the corporate action processing available to cater for Term DBVs is described per generic corporate action type. The generic types covered are:

- **Distributions** – the underlying security remains unchanged, but holders receive additional shares or cash. E.g. Dividend/Interest Payment or Capitalisation Issue.
- **Mandatory Reorganisations** – the underlying security is replaced by one or more new resources. E.g. Consolidation or Final Redemption.
- **Mandatory Reorganisations with Options** – the underlying security is replaced by one or more new resources, but the holder has a choice of outturns. E.g. Takeover by Scheme or Rights Issue Call Payment
- **Voluntary Reorganisations** – holders may elect to exchange their underlying security for one or more new resources. If they choose not to participate the underlying holding remains unchanged. E.g. Takeover or Warrant subscription.

General principles for Term DBVs

To manage the impact of corporate actions on Term DBVs:

- On creation, the DBV security allocation algorithm will exclude securities that have corporate actions (which could impact the collateral security)⁵⁴ from being allocated to the Term DBV (See ‘Exclusion of securities’ in Section 2).
- If a security is allocated to a Term DBV but then subsequently becomes subject to a corporate action, the CREST system will attempt to substitute out that security on the day before the record date of the corporate action using the overnight Term DBV Eligibility (TDE) Substitutions functionality.

Note: As a general rule, with exception of cash distributions, the CREST system will attempt to substitute out all securities that are subject to corporate actions that are mandatory/mandatory with options. There will be no attempt to substitute for voluntary events.

The successful settlement of such substitutions will therefore help circumvent the need for claims and automatic transformations in those scenarios.

If automatic substitution is not possible or the substitution transactions have not settled⁵⁵ by close of business on the record date, one of the following standard corporate action functionality will be employed to manage the open positions:

- Claims (see Section 11) – for open TDRs where the constituent security is subject to a **Distribution** type corporate action.

⁵⁴ These corporate actions are identified by the CREST system via the ‘DBV Exclusion’ attribute of the corporate action which is set to indicate ‘Yes’.

⁵⁵ The CREST system attempts to generate the substitution on the day before record date. Therefore, in the case of failed automatic substitutions, members will still have a window of opportunity on record date, until close of business, to employ manual substitutions.

In this situation the Collateral Taker will be on the share register as owner and will be paid the proceeds by the Issuer. To reposition these proceeds to the correct counterparty (Collateral Giver), the CREST system will generate a Claim transaction in relation to the open TDR.

- Automatic Transformations (see Section 12) – for open TDRs where the constituent security is subject to a **Reorganisation** type corporate action.

In this situation, the CREST system will carry out additional processing, as follows, to manage the impact on the open TDR:

- 1) The CREST system will transform the open TDR into the new outturn proceeds as follows:
 - a) For the case of security proceeds, the transformation will result in the open TDR being replaced by a new TDR in the security proceed.
 - b) For cash only proceeds, the transformation will result in up to two cash only delivery transactions⁵⁶ as follows:
 - i. a DEL replacing the open TDR to deliver the outturn cash proceed from the collateral taker to the collateral giver; and
 - ii. a separate DEL (if the open TDR had consideration), to deliver the consideration part from the Collateral Giver to the Collateral Taker.
- 2) As a result of the above transformation, the Term DBV could potentially be over- or under-collateralised, i.e. if there is a cash proceed involved, or if the collateral (proceed) security in the newly created TDR is not the same collateral value as the original security, or if the proceed security is ineligible for inclusion in the Term DBV. In these situations, the CREST system will attempt to handle these discrepancies as follows:
 - a. First the overnight TDE substitutions process will be invoked (See Section 8). The process will identify those securities that can no longer be included⁵⁷ in the Term DBV and will attempt to replace them with other collateral of equivalent value from the Collateral Giver.
 - b. Following the TDE substitutions process, the CREST system will invoke the mark-to-market process. The mark-to-market process will assess the collateral value of all TDRs in the Term DBV as a whole and attempt to ensure that it is correctly balanced by generating a TDM transaction as appropriate (See Section 9).

⁵⁶ Members should note that transformations involving a cash outturn will in effect reduce of the collateral that is assigned to the Term DBV itself.

⁵⁷ For example: where a newly created TDR (as a result of a transformation) includes a security that is not in the correct DBV class.

Gilts processing

Currently there is no open transaction management processing associated with Gilts (as the Gilts registrar record is struck intraday – see Section 13). With Term DBVs, there will be an important change to the Gilts processing. This change could potentially affect all holders of Gilts and is not limited to Term DBV users.

The changes to Gilts processing are described in Section 13.

Eligible Debt Securities (EDSs)

For EDS (also known as Money Market Instruments) redemptions, in line with existing processing, automatic transformations and claims will not be applicable. Instead, the standard EDS maturity process will be extended to treat open TDRs in the same way as open SLRs, DBRs and RPRs.

For any open collateral return transactions, the EDS maturity process automatically creates DEL transactions to deliver the maturity payment⁵⁸ from the EDS Issuing and Paying Agent (IPA) to the initial Collateral Giver in return for the underlying security.

Note: Settlement of these generated DELs (and hence the payment to collateral giver) depends on the Collateral Taker returning the EDS security to the Collateral Giver.

For EDS interest payments, in line with existing processing, claims will only be applicable for interim interest payments. Claims will not be generated for the final interest payment which is paid with the redemption.

⁵⁸ **Note:** This payment also includes the final interest payment where applicable.

Section 11: Claims processing

Term DBV return (TDR) transactions may exist over the record date for a distribution corporate action of the underlying constituent security. To reposition distributions that are received by the incorrect counterparty, we will include open TDRs within the Claims Processing Unit (CPU) to redistribute benefits through the settlement of centrally generated claim transactions.

However, including TDRs in the CPU will depend on the category of security contained within the transaction. Currently, only equities and EDSs⁵⁹ are included in the CPU. When the Term DBV functionality service is implemented, Gilts will also be assessed for claims by the CPU (See Section 13).

Claims created from a TDR will be dealt with in the same way as other claims within the CREST system, i.e. the claim transactions will be created with an intended settlement date equal to the payment date of the corporate action and given a priority of 50.

Security distributions

Unlike Cash distributions, Security distributions often have a diluting effect on the value of the underlying security and, in turn, the collateralisation of a Term DBV. Thus, for Term DBVs, if the constituent security is subject to a 'security distribution' type corporate action, the CREST system will attempt (on the day before the record date) to replace that security by using the overnight TDE substitutions functionality (See Section 9).

Claims processing (relating to security distributions) will therefore only take place if the TDE substitutions fail to be generated or could not settle. If the TDEs have failed to generate/settle, members will still have an opportunity on the record date (until the close of business) to perform manual substitutions (TDS).

⁵⁹ **Note:** For EDSs, generation of claims is only ever considered for the interim interest payments (See Section 10).

Section 12: Automatic transformations

Term DBV return (TDR) transactions will be included within automatic transformations. This section describes the processing that will be applicable to Term DBVs for the different generic corporate action types:

- Mandatory reorganisations;
- Mandatory reorganisations with options; and
- Voluntary reorganisations.

Mandatory reorganisation

For mandatory reorganisation type corporate actions, the CREST system will centrally transform any open TDRs from ‘transformation date’ (typically the record date) onwards, as is currently the case.

On the day before the record date of the mandatory reorganisation corporate action, the central TDE substitutions process will attempt to substitute the corporate action security out of the term DBV. Therefore, automatic transformations will only take place if the TDE substitutions failed to be generated or could not settle.

Note: If the TDE substitutions fail to generate/settle, members will still have an opportunity on the record date (until close of business) to perform manual substitutions (TDS).

Transforming a TDR could result in an exposure arising between the counterparties to a Term DBV. Members will be able to view these exposures via the Exposure enquiries (See Section 3).

In the same overnight processing, transformations will be followed initially by the central TDE substitutions process, which will attempt to identify and replace the collateral that may no longer be included in the Term DBV.

The TDE substitutions process will be followed by the mark-to-market process, which will centrally attempt to rebalance the Term DBV within the same overnight processing.

Note: Members may want to perform manual substitutions (TDS):

- before the transformation date, to avoid the impact of the transformation; or
- after the transformation date, in the event that the central mark-to-market process was unsuccessful.

Example: Case A – Single Outturn Security

If the outturn proceeds to a corporate action is a single line of security, the TDR transaction will transform as follows:

- The original TDR transaction will be given a transformed status and will be centrally deleted.
- A new outturn TDR transaction will be created in the new line of security. The new TDR will have the same consideration as that of the deleted TDR and a security quantity that will be based on the benefit ratio of the corporate action. Additionally, the new TDR will also have the same intended settlement date and origin transaction ID/origin transaction ref as that of the deleted TDR transaction.

The transformation process will be followed by the central overnight TDE substitutions process. If the new security is not in the same DBV class as the underlying term DBV, a TDE substitution will centrally be generated to replace the new constituent security. Unless the new security is already able to settle and the Collateral Taker is already a holder of sufficient quantity of the new security, the TDE substitution will fail to settle until the Collateral Taker (as the record date entitled holder) receives the new security on the corporate action payment date. In the interim period between the record date and the payment date, members will need to manually intervene if such a situation is not desirable.

Independent to the issue of the DBV class of the security, the value of collateral in the Term DBV may be imbalanced if the value of the new security is higher or lower than the original line. The mark-to-market functionality will attempt to rebalance the collateral to ensure that the Term DBV is properly collateralised⁶⁰.

Example: Case B – Multiple Outturn Security Lines

If the outturn proceeds have more than one line of security, the TDR transaction will transform as follows:

- The original TDR transaction will be given a transformed status and will be centrally deleted.
- A new outturn TDR transaction will be created for each new line of security. The consideration of the deleted TDR will be split across the new TDR transactions based on the benefit percentage indicated in the corporate action (KCAP). The quantity of security in each of the new TDR transactions will be determined based on the benefit ratio of each outturn security. Each of the new TDRs will have the same intended settlement date and origin transaction ID/origin transaction ref as that of the deleted TDR transaction.

The same principles will apply for central TDE substitutions and mark-to-market processing, as described above in example Case A.

Example: Case C - Mixture of Security and Cash Outturns

If the outturn proceeds have both security and cash elements, the TDR transaction will transform as follows:

- The original TDR will be given a status of transformed and will be centrally deleted.
- Security Outturn:
 - A new outturn TDR transaction will be created:
 - in the new line of security, as per example Case A; or
 - in each new line of security (if there is more than one security outturn), as per example Case B.
- Cash Outturn:
 - The cash element of the outturn will be created as a separate cash only delivery transaction. The value of the cash element will be based on the benefit ratio indicated on the corporate action. The transaction repatriates the cash outturn from the Collateral Taker (who will receive the same proceeds on the payment date from the corporate action receiving agent) to the Collateral Giver.

⁶⁰ Mark-to-market alignment is only performed when a price is available in the CREST system for all the collateral securities of a Term DBV.

Note: New securities will, in general, only have a price on the security start date. Therefore, in between the record date and the security start date, mark-to-market alignment will not take place if the new security has a zero price (See Section 9).

- The cash only DEL will be linked to the TDO via origin fields, and it will reference the transaction ID of the original TDR in the ‘Transform Transaction ID’ field.
- The intended settlement date of the cash only DEL will be set to the payment date of the corporate action⁶¹.
- The cash outturn effectively removes the equivalent collateral value from the DBV.

The same principles will apply for central TDE substitutions and mark-to-market processing, as described above in example Case A.

Example: Case D – Cash Only Outturn

If the outturn is cash only, the original TDR will be transformed as follows:

- The original TDR will be given a status of transformed and will be centrally deleted.
- If the original TDR had a consideration, a new DEL transaction will be created to deliver the consideration from the Collateral Giver to the Collateral Taker. The DEL transaction will have the same intended settlement date as the deleted TDR transaction.

Note: Since settlement of TDM transactions results in the re-apportionment of the Term DBV consideration across all TDRs, this DEL transaction in effect becomes redundant and will be centrally deleted on settlement of a relating TDM transaction⁶².

- For the cash outturn, a separate cash only delivery transaction will be created to deliver the proceed from the Collateral Taker to the Collateral Giver (as per example Case C).

Note: The intended settlement date of this cash only DEL transaction is set to the corporate action payment date.

The same principles will apply with regard to mark-to-market processing, as described above in example Case A.

Note: In this scenario there will no longer be a relating TDR.

Example: Case E – Outturn Security is already a collateral security of the Term DBV

If the event occurs before the transformation, and there already exists a TDR in the outturn security of the corporate action, then to avoid having more than one TDR (for the Term DBV) with the same security, the following processing will be applied:

- The original TDR transaction will be given a status of transformed and will be centrally deleted and replaced by a new outturn TDR transaction in the new line of security exactly as described in Case A.
- At this point there will be two TDRs in the outturn security – one that existed before the transformation and one created as a result of the transformation. Both these TDRs will be centrally deleted and replaced by a new TDR, combining the security quantity and, if applicable, the cash consideration amount of the two deleted TDRs.

This transformation processing will be followed by the same overnight substitution and market-to-market processing as described in Case A.

⁶¹ This is different to the equivalent processing that currently exists for Open/Term Repos (i.e. the intended settlement date of the delivery transaction is set to the same intended settlement date as that of the deleted RPR transaction).

⁶² In the same overnight as that of the transformation, the mark-to-market process will have created a TDM transaction to balance the Term DBV collateral. Where the TDM fails to generate/settle, the DEL transaction will continue to exist until either a TDM is generated and settled subsequently, or the ISD of the DEL is reached and the DEL settles.

Mandatory reorganisations with options

Similar to mandatory reorganisation corporate actions, the CREST system will centrally transform open TDRs as from the **Transformation Date** (typically the record date).

The TDE substitutions process will attempt centrally to substitute the securities out of the Term DBVs on the day before the record date, and automatic transformations will only take place if such TDE substitution transactions failed to be generated or could not settle.

If either counterparty has entered a buyer protection/transformation instruction (ACON), or both parties match buyer protection/transformation instructions, transformation will be for the option selected. In the absence of such ACON instructions or non-matching ACONs, the transformation will be in accordance with the default option.

Collateral Takers that are making onward elections⁶³ based on any such ACON instructions from the Collateral Giver, close to the record date, should be aware that there may be a relating TDE substitution (generated overnight on the day preceding record date) that could settle on the record date and return the securities (subject of the ACON instruction) back to the Collateral Giver.

Voluntary reorganisations

There is no central generation of TDE substitutions for open TDRs impacted by voluntary corporate actions. Where Collateral Givers subject to open TDRs want to participate directly in these events, they will be required to manually substitute (on a matched basis) or make other arrangements with their counterparty to retrieve the relevant security.

The CREST system will centrally transform open TDRs triggered by the presence of matched Buyer Protection/Transformation instructions (ACONs) from the Collateral Giver and Taker. Transformation will take place overnight on the day that the Buyer Protection instructions match.

Skipping transformations

As per the current automatic transformation functionality, members will be able to choose to skip the transformation for a TDR. If both the counterparties choose to skip the transformation, the TDR transaction will become centrally deleted on the expiry of the constituent security, resulting in the Term DBV becoming under-collateralised. However, in the same overnight as the deletion of the TDR, the central mark-to-market process will attempt to rebalance the collateral to ensure that the Term DBV is properly collateralised.

Call payments

For open TDRs involving a constituent security which is a nil paid right (or any other subscription security) that is subject to a call payment corporate action, the automatic transformations processing will take account of the call payment that would have been paid by the Collateral Taker to the issuer to acquire the fully paid security on behalf of the Collateral Giver.

Upon transforming a TDR in a nil paid rights security:

- A separate cash only DEL will be generated from the Collateral Giver to the Collateral Taker to account for the call payment made by the Collateral Taker. The **Intended Settlement Date** of this cash only DEL will be set to the current date and the **Transform Transaction ID** field will be set to the TDR transaction ID.

⁶³ That is, corporate action elections (TTE/USE) that might be input by the stock holder (on behalf of the counterparty) on record date or the day preceding record date.

- The term DBV as a whole will become over-collateralised given that the fully paid security into which the TDR has been transformed will have a greater value than the nil paid right security. This imbalance, however, will be rectified by the mark-to-market process which will follow automatic transformations.

Note: For TDRs, given the automatic mark-to-market processing, this transformation processing is slightly different to that employed for Repo Returns (RPRs). As mentioned above, the Term DBV as a whole will be over-collateralised after the transformation and, thus, the mark-to-market process will generate a TDM to deliver the excess collateral to the Collateral Giver. The separate cash only delivery created will act to compensate the Collateral Taker for the call payment they will have paid out to obtain that extra collateral value.

Section 13: Gilts Processing

End of day record

With the introduction of Term DBVs (but independent to its usage), and in line with the European Commission CAJWG⁶⁴ standards, there will be a change in the way that the record is struck for interest payments of Gilts.

Currently, the record is struck intraday. This occurs after DVP settlement is completed, but before the start of overnight DBV settlement. At this stage, the ‘giver’ parties to collateral transactions are still on the register and will therefore appear on the record. Accordingly, although Collateral Takers are the registered holders after settlement of any ensuing DBV transactions, interest payments are made in line with the intraday record. The Collateral Givers then receive their interest payments directly from the Gilts registrar. There is currently no claims processing associated with Gilts.

With the introduction of Term DBVs it will no longer be possible to make payments to Collateral Givers by striking the record date register intraday. This is because there may already be a number of Term DBV transactions present in the system before the record date. With the Term DBV service, the record will now be struck at the end of the day and, where appropriate, the CPU will be employed to reposition interest payments to the correct counterparty.

Note: This change affects all holders of Gilts (**Term and Overnight DBVs** as well as holders party to Gilts Stock Lending transactions, as these transactions will all now be subject to claims processing).

Gilt Interest and Redemption Payment mechanism

The Gilts registrar currently pays redemption and interest payments either by cheque or, more often, by BACS, using the payment instructions supplied by the Gilts holder. To support the introduction of claims processing for Gilts, the registrar will also provide an optional facility to make these payments via the CREST system⁶⁵ by instruction type USE. The USE instruction will be created at member account level and upon settlement, in line with all other CREST payments, will credit the CMA associated with the relevant Participant.

Gilts holders will be able to advise the registrar that payments are required via the CREST system by use of a ‘**Mandate**’ flag (on participant details). It will be possible to instruct at participant level to receive either Gilt interest or redemption or both payments via the CSD⁶⁶. Members will need to contact Euroclear UK & Ireland Operations to record or amend such instructions.⁶⁷

Members who opt to receive their Gilts payments via the CREST system should liaise with their settlement banks about intraday access to these payments.

Claims on Gilts

The CPU will assess claims on open transactions in Gilts as from the record date of the underlying distribution corporate action, and continue to assess during each overnight processing until payment date +5 days, as per existing CPU procedure. However, given the typical processing protocol observed for Gilts transactions, it is unlikely that there will be any relevant transactions after the record date.

⁶⁴ Corporate Action Joint Working Group to address Giovannini Barrier 3.

⁶⁵ This new facility will offset the credit impact of the demand for cash from the Claim.

⁶⁶ Members may also use the ‘mandate’ flag to receive dividend payments on equities via the CSD; this is existing processing.

Note: The ‘mandate’ flag will use a new set of values with the introduction of the Term DBV service (members should refer to the appropriate Euroclear UK & Ireland Data Exchange Manual for the new set of values).

⁶⁷ More details and specimen documentation will be available in due course.

With Term DBVs, the CPU will select transactions to assess for claims as follows:

- For all collateral transactions (SLR, RPR, DBR, and TDRs): if the transaction is unsettled as at close of business on record date.
- For all other transaction types other than a DEL in a Gilts: as per existing CPU processing.

Note: DELs have been specifically excluded following feedback from the Client Working Group. The other transaction types include CLAs and MTMs, both of which will be rare in the context of Gilts.

Transformations on Gilts

On the day before the Payment Date of a redemption corporate action, the CREST system will centrally transform any open TDRs in the related Gilts. The TDRs will be transformed as follows:

- The original TDR will be given a status of transformed and will be centrally deleted.
- If the original TDR had a consideration, a new cash only transaction will be created to deliver the consideration from the Collateral Giver to the Collateral Taker. The transaction will have the same intended settlement date as that of the deleted TDR transaction.
- For the redemption payment, a separate cash only transaction will be created to deliver the proceeds from the Collateral Taker to the Collateral Giver. This transaction will have an intended settlement date of the corporate action payment date and a priority of zero (frozen)⁶⁸.

⁶⁸ Setting the priority to zero for transactions related to the proceeds, will allow Collateral Takers to appropriately manage the settlement of these transactions on the basis of receipt of the relating proceeds.

Section 14: Miscellaneous

CREST system diary for Term DBVs

New CREST diary events introduced for the Term DBV service have been covered in the previous sections of this document. These diary events, including their exact timing, will be incorporated in an updated version of the CREST White Book ‘CREST diary events and daily timetable’.

Settlement discipline

Changes to settlement discipline for the Term DBV service are being discussed and agreed with the Settlement Discipline Committee.

Any changes to settlement discipline as a result of the discussions will be notified to the market and incorporated in an updated version of the associated white book: ‘CREST Settlement Discipline: Overview of rules and common questions’.

SDRT

UK SDRT

Term DBV transactions (TDO, TDR, TDS, TDG TDE, TDM and TDA) will be assessed for Stamp Duty Reserve Tax (SDRT).

Details of how transactions are assessed and how relief is applied will be incorporated in an updated version of the CREST White Book ‘UK Stamp Duty Reserve Tax: relief for principal traders’.

Ireland – stamp duty

Currently, all loan type (stock borrowing) transactions for Irish chargeable securities are exempt from Irish stamp duty. Term DBV transactions will therefore also be exempt.

US securities

Euroclear UK & Ireland is not registered as a ‘clearing agency’ with the US Securities and Exchange Commission (SEC), and does not have the benefit of an order exempting it from the requirement to be registered as such. Therefore, we are unable to settle transactions in securities issued by US domestic issuers for our US members (a US member is defined, for these purposes, as a member resident or incorporated in the US or registered as a broker-dealer with the SEC).

We have therefore planned an update to the CREST system, to be implemented in 2011, after the implementation of the Term DBV service, to ensure that US securities (defined for these purposes as a security with an ISIN prefix ‘US’ and any security subject to the restrictions in Category 3 of Regulation S) cannot settle into accounts of our US members.

The DBV Security Allocation process, from the launch of the Term DBV functionality, will prevent the selection of US securities i.e. those with a US ISIN, for a DBV (whether a Term or Overnight DBV) if the Collateral Taker is a participant of a US member.

Section 15: Adjustments to DBV Value Sought and Consideration

The CREST system will provide new functionality to allow members to manage the following two attributes of a Term DBV:

- **DBV Value Sought** – to allow the DBV Value Sought of a Term DBV to be increased or decreased following any new arrangement of members.
Note: The CREST system will use a technical field called **Base Value Sought** to represent the last agreed DBV Value Sought of the Term DBV (See definition further below in this section).⁶⁹
- **Consideration** – to allow the consideration of a Term DBV to be increased or decreased following any new arrangement of members

Members will also be able to use this new functionality to realign the value of collateral in a Term DBV to be in line with the **DBV Value Sought** amount.

Term DBV Adjustment List enquiry

Members will be able to view a list of their Term DBV Adjustment (TDA) instructions, both settled (i.e. historic)⁷⁰ and unsettled (i.e. still pending) using a new enquiry called **Term DBV Adjustment List**. The enquiry will be available via both file transfer and the interactive GUI (NTAQ/NTAL).

Members will have the following selection criteria for both the file transfer and the interactive GUI enquiries:

- Origin Transaction ID (optional)
- Origin Transaction Reference (optional)
- Date Range fields (optional)

The Transaction ID and/or Transaction Reference of the related Term DBV transaction (the TDO) must be specified in the 'Origin' fields mentioned above, either individually or in combination with the Date Range selection criteria.

Members will be able to specify a Date Range (Selection Date From and Selection Date To) to restrict the retrieved list of TDA instructions to those that have an intended settlement date which falls within the specified date range.

The response message to the enquiry will return the following details:

- **Current Market Value**
The Current Market Value field will show the current value of the collateral actually allocated in the Term DBV (i.e. including any collateral needed to cover the DBV Margin or BoE Haircut that may be applicable) based on the last reference prices available on the CREST system.
- Consideration (*of the TDO*) – returned only for the interactive GUI response
- DBV Value Sought (*of the TDO*) – returned only for the interactive GUI response

⁶⁹ On the initial setup of the Term DBV, the field used is 'DBV Value Sought'; thereafter the amount applicable for the DBV Value Sought will be represented in the CREST system by 'Base Value Sought' (this is the field name that will be displayed on all the collateral management screens and will be used in the various messages).

⁷⁰ All data shown (e.g. Base Value Sought, Next Base Value Sought etc) for historic records will represent the data that was applicable at the time of the instruction.

- DBV Margin (*of the TDO*) – returned only for the interactive GUI response
- Apply BoE Haircut (*of the TDO*) – returned only for the interactive GUI response
- Transaction ID (*of the TDA*) [Repeating]
- Transaction Reference (*of the TDA*) [Repeating]
- Intended Settlement Date (*of the TDA*) [Repeating]
- Next Base Value Sought (*of the TDA*) [Repeating]
- Next Consideration (*of the TDA*) [Repeating]
- DBV Party Status (*of the TDA*) [Repeating]
- DBV Status (*of the TDA*) [Repeating]
- Failure Reason Code (*code identifying the reason why a TDA has not settled*) [Repeating]

Note:

The File Transfer enquiry response also returns the following additional fields (these fields are not returned by the interactive GUI response). Members using the interactive GUI functionality can retrieve the equivalent information via the Term DBV Adjustment Details (NTAQ) enquiry (as described below).

- Origin Transaction ID (*Transaction Id of TDO*)
- Origin Transaction Reference (*Transaction Reference of TDO*)
- Base Consideration (*See description of the NTAR message below for definition*)
- Base Value Sought (*See description of the NTAR message below for definition*)
- Last Equivalent Value Sought (*See description of the NTAR message below for definition*)

Term DBV Adjustment Details enquiry

Members will be able to retrieve the full details of a single unsettled (or settled) Term DBV Adjustment instruction using a new enquiry called **Term DBV Adjustment Details**. The enquiry is only available via the interactive GUI (**NTAR**). For file transfer, the equivalent details are returned as part of the Term DBV Adjustment List enquiry (NTAQ -see above).

Members will have the following selection criteria:

- Transaction ID (optional)
- Transaction Reference (optional)

Either the Transaction ID and/or the Transaction Reference of the related TDA instruction must be specified.

The response message to the enquiry will return the following details for the TDA instruction:

- Transaction ID (*of the TDA*)
- Transaction Reference (*of the TDA*)
- Intended Settlement Date (*of the TDA*)
- Party Transaction Status (*of the TDA*)
- Transaction Status (*of the TDA*)
- Reason Code (*code identifying the reason why a TDA has not settled*)
- Origin Transaction ID (*Transaction ID of TDO*)

- Origin Transaction Reference (*Transaction Reference of TDO*)
- DBV Margin (*of the TDO*)
- Apply BoE Haircut (*of the TDO*)

- **Base Consideration**

The Base Consideration field will show the original Consideration amount or the most recently agreed Consideration of the Term DBV where this has been amended using a TDA instruction. For example, if the Term DBV was set up with a Consideration of GBP 100m, but subsequently the Consideration was amended to be GBP 175m (via TDA instruction), the Base Consideration will be GBP 175m.

- **Base Value Sought**

The Base Value Sought field will show the original DBV Value Sought amount or the most recently agreed DBV Value Sought of the Term DBV where this has been amended using a TDA instruction. For example, if the Term DBV is set up with a DBV Value Sought of GBP 100m, then, unless the member enters a new DBV Value Sought (via TDA instruction), the Base Value Sought will remain at GBP 100m.

- **Last Equivalent Value Sought⁷¹**

The Last Equivalent Value Sought field will show the adjusted current market value of the Term DBV; i.e. the market value of the Term DBV collateral (excluding any extra collateral that is needed to satisfy any applicable DBV Margin or BoE Haircut) based on the last reference prices available on the CREST system. For example, if the current market value of the collateral in a Term DBV is GBP 220m and the Term DBV was set up with an applicable margin of 10%, the Last Equivalent Value Sought amount will show GBP 200m. The Last Equivalent Value Sought amount is updated on a daily basis as part of the CREST system overnight processing (after reference prices have been updated).

- **Next Base Value Sought** (*See description of the NTAN message below for definition*)
- **Next Consideration** (*See description of the NTAN message below for definition*)

Inputting a Term DBV Adjustment instruction

The **Term DBV Adjustment instruction** (NTAN) will allow members to amend the DBV Value Sought and Consideration attributes of Term DBVs that have not reached their return date. Additionally, in the event of over or under-collateralisation, the instruction will allow members to re-collateralise the Term DBV correctly according to the DBV Value Sought of the Term DBV (i.e. thereby in effect performing an intraday mark-to-market adjustment)⁷².

The Term DBV Adjustment instruction (NTAN) will be available via both file transfer and the interactive GUI.

In the case of the interactive GUI, members will be able to input the NTAN instruction using the new GUI screen called '**Term DBV Adjustment Details**' (See relating function description above). The screen will display the **Base Value Sought** and **Consideration** fields related to a Term DBV. It will also display the **Last Equivalent Value Sought** field (i.e. the current adjusted market value of the Term DBV Collateral, based on the last reference prices available to the CREST system)⁷³.

⁷¹ **Note:** The CREST GUI screen will display a difference between the Last Equivalent Value Sought amount and the Base Value Sought amount figures to allow members to easily see if they under or over-collateralised.

⁷² **Note:** Any realignment of the Term DBV collateral will be inclusive of any applicable DBV Margin or BoE Haircut.

⁷³ This 'Last Equivalent Value Sought' will indicate the new DBV Value Sought that a member should enter should they want the Term DBV to be correctly collateralised based on the current value of the collateral in the Term DBV.

The Term DBV Adjustment Instruction (NTAN) message will require members to enter data for the following fields:

- Transaction Reference (*member specified reference to be given to the TDA*)
- Origin Transaction ID (*the transaction id of the TDO*)
- Origin Transaction Reference (*the transaction ref of the TDO*)
- Next Base Value Sought (*new Base Value Sought applicable to the Term DBV*)
- Next Consideration (*new Consideration applicable to the Term DBV*)

Members will need to specify either the Transaction ID or the Transaction Reference of the related Term DBV transaction (the TDO) in the ‘Origin’ fields mentioned above. The new DBV Value Sought amount applicable to a Term DBV will need to be specified using the **Next Base Value Sought** field, whilst an amendment to the Consideration must be specified using the **Next Consideration** field.

It will be possible to amend the two attributes (DBV Value Sought and Consideration) of the Term DBV independently of each other or in combination. However, in all cases, values for both attributes must be specified in the adjustment instruction. If only one attribute is amended, the member must confirm the current value of the Term DBV for the attribute that is not being amended.

If the DBV Value Sought of a Term DBV is amended, an intraday alignment of the Term DBV will take place to ensure that the Term DBV is correctly collateralised in relation to the specified **Next Base Value Sought** field.

Note: Where a Term DBV is under or over-collateralised, members may wish to specify the ‘Last Equivalent Value Sought’ figure in the **Next Base Value Sought** field; this will have the effect of setting the DBV Value Sought of the Term DBV to the current adjusted market value and thus correctly rebalance the Term DBV without any collateral adjustments.

If a Term DBV is under or over-collateralised, reaffirming the current base values of the Term DBV in the next value fields of the NTAN instruction will allow members to realign the collateral value of the Term DBV to be correctly collateralised in relation to the current DBV Value Sought.

Members will not be permitted to amend the DBV Value Sought of a Term DBV to zero.

Amendment of the Term DBV Consideration amount will lead to a cash payment as follows:

- If the ‘Consideration’ is increased, the cash payment will be made from the Collateral Taker to the Collateral Giver.
- If the ‘Consideration’ is decreased, the cash payment will be made from the Collateral Giver to the Collateral Taker.

Amendment of the ‘Consideration’ will be permitted only for those Term DBVs that were created with a consideration (i.e. a non-zero value) on initial set up. Members will not be allowed to decrease the value of the Term DBV consideration to zero.

Input of Term DBV Adjustment instructions will require matching, as changes to either of the two attributes will need agreement from both parties. Only one Term DBV Adjustment instruction at a time may be matched per Term DBV.

Members will be able to view adjustments that they have input and/or adjustments that have been alleged against them using a new enquiry called ‘**Term DBV Adjustment List**’ (See below).

Term DBV Adjustment Instructions may be input and matched as from the system opening at 04:00 GMT. However, the instructions will only be considered for settlement during the DBV settlement window (15:00 to 16:10 GMT). The instructions may be input only for settlement on the current business day. Forward-dated amendments will not be permitted.

Members will not be able to carry out any further adjustments to Term DBVs after the ‘DBV input disable’ diary event (16:02 GMT) on the business day before Term DBV return date.

Settlement of a Term DBV Adjustment instruction

Term DBV Adjustment instructions will be settled during the DBV settlement window as described in the table below. The adjustment to the Term DBV will be made using the new transaction type ‘Term DBV Adjustment’ (TDA). The CREST system will use the transaction to vary the stock and/or consideration of a Term DBV. As a result, the movements of the TDA transaction may consist of stock only, cash only, stock with cash (same direction), stock versus cash or in the exceptional case no movements (See below).

Step	Description
1	To correctly collateralise the Term DBV for the specified Next Base Value Sought amount, the CREST system will determine the collateral adjustment required (if any) for the Term DBV as the difference between Next Base Value Sought and Last Equivalent Value Sought (taking into consideration any applicable DBV Margin or BoE Haircut).
2	If the Term DBV (based upon Next Base Value Sought) is under-collateralised, additional collateral (to a value as determined by step 1) must be allocated to the Collateral Taker. The additional collateral required will be selected on the same basis as that of the related Term DBV (i.e. respecting the Concentration Limit, DBV Class, DBV Margin, etc as that of the original TDO transaction). If no additional collateral can be allocated, the TDA transaction will not be created.
3	If the Term DBV (based upon Next Base Value Sought) is over-collateralised, collateral from the Term DBV must be selected for recall (to a value as determined by step 1) and return to the Collateral Giver. The TDA will not be created if the Collateral Taker has insufficient securities in the relating member account.
4	If the Consideration of the Term DBV is being increased or decreased, the CREST system will validate the relating CAP of the cash debit party.
5	If the CREST system has determined that a TDA can be generated, the TDA transaction will be created as follows: <ul style="list-style-type: none"> • If the Term DBV is under or over-collateralised, the TDA will include stock movements to deliver the selected collateral securities to the Collateral Giver or Collateral Taker (as appropriate). <p>Note: If the ‘DBV Value Sought’ of the Term DBV is amended to be the same as the current adjusted market value of the Term DBV (i.e. as indicated by the ‘Last Equivalent Value Sought’ amount), no collateral adjustment will be required. Thus in this instance, if the adjustment was only for the ‘DBV Value Sought’, the TDA transaction generated will have no associated movements (i.e. stock or cash).</p> <ul style="list-style-type: none"> • If the Term DBV ‘Consideration’ amount is amended, the TDA will include a cash movement from the Collateral Taker to the Collateral Giver or from the Collateral Giver to the Collateral Taker (as appropriate). • The TDA transaction will be created for settlement at priority 91. • The Origin Transaction ID and Origin Transaction Reference fields of the TDA will be populated with the Transaction ID/Transaction Reference of the original TDO. • A file change will be generated for each of the counterparties to the TDA.
6	Settlement of a TDA transaction will result in: <ul style="list-style-type: none"> • updating the base values (Base Value Sought and/or Base Consideration, as appropriate) for the Term DBV where either one or both attributes of the Term DBV are amended by the TDA instruction; • deleting and/or creating a Term DBV return (TDR) transaction (and appropriate file changes) for each collateral security movement specified in the TDA transaction; and • re-apportion the revised (or original) Term DBV consideration (if applicable) across all the TDR transactions so that the consideration on each of the TDR is a fair reflection of the actual value of the collateral in the TDR.
7	At the end of the DBV settlement window, Term DBV Adjustment instructions that still remain unsettled will be centrally rejected.

Amending and Deleting a Term DBV Adjustment instruction

It will not be possible for members to amend Term DBV Adjustment instructions. If members wish to amend the Next DBV Value Sought and/or Consideration fields of a pending Term DBV adjustment instruction they will need to delete and re-input the instruction before it settles instead.

Members will be able to delete Term DBV Adjustment instructions before settlement of the TDA transaction, by using the existing **DBV Instruction Delete (NDDD)** function. This function is available via both file transfer and the interactive GUI.

Term DBV Adjustment instructions that have been input and matched, but where the TDA transaction has not settled, may be deleted⁷⁴ but will require both parties to input a deletion. Otherwise the Term DBV Adjustment instruction will continue to be considered for settlement in the normal manner. If, at the end of day (DBV settlement window), the TDA transaction still remains unsettled, the Term DBV Adjustment instruction will be rejected.

TDA status values

The TDA instruction may undergo the following status changes:

TDA instructions	You	Counterparty	Transaction	Description
	B	A	A	My input unmatched
	A	B	A	Counterparty input unmatched (alleged against me)
	I	I	E	Instructions matched and ready to action (settle)
	X	X	F	Settled – TDA transaction generated
	I	I	R	Instruction rejected. No transaction generated
	Z	Z	Z	Archived
Deletions	F	F	C	I deleted my unmatched input
	F	F	C	Counterparty deleted its unmatched input
	D	E	E	I delete a ready TDA instruction
	E	D	E	Counterparty deletes a ready TDA instruction
	F	F	C	Deletion matched, TDA instruction deleted

The TDA transaction may undergo the following status changes:

TDA transactions	You	Counterparty	Transaction	Description
	Y	Y	F	Complete, no registration needed
	Y	Y	G	Actioned (settled), awaiting registration, (only applies to non ETT securities)
	Y	Y	H	Bad delivered (non ETT securities only)
	Y	Y	I	Complete, all lines of security registered
	Y	Y	J	Complete, one or more lines of security bad delivered (non ETT securities only)
	Z	Z	Z	Archived

If the TDO transaction contains a mixture of securities – some of which need registration and some of which do not – the transaction will change to a status of ‘Complete, all registered’ (YYI) only once all of the the securities that need registration are successfully registered.

⁷⁴ Members will not be able to delete a matched Term DBV Adjustment instruction that has successfully settled a Term DBV Adjustment transaction.

DBV Instruction List Enquiry

The existing **DBV (Instruction) List (NDDL)** enquiry will be enhanced to also report TDA instructions.

Members will be able to identify the TDA instructions via the new ‘**Transaction Type**’ field of the response message (See Section 2).

Term DBV Transaction List enquiry

Members will be able to view the full set of transactions (TDR, TDI, TDG, TDE, TDM, TDS, TDA, DEL and CLA) related to a Term DBV using a new enquiry called **Term DBV Transaction List**. The enquiry will be available via both file transfer and the interactive GUI (NTTQ/NTTL).

Members will have the following selection criteria for the interactive GUI enquiry:

- Origin Transaction Id (optional)
- Origin Transaction Reference (optional)
- Date Range fields (optional)
- Selection Transaction Type (optional)
- Selection Transaction Status (optional)
- Inactive Returns (optional)

The Transaction ID and/or Transaction Reference of the related Term DBV transaction (the TDO) must be specified either individually or in combination with one or more of the other selection criteria.

Members will be able to specify a Date Range (Selection Date From and Selection Date To fields) to restrict the retrieved list of transactions to those that have an intended settlement date which falls within the specified date range.

The Selection Transaction Type field will allow members to restrict the retrieved list of transactions to the specified single transaction type.

The Selection Transaction Status field will allow members to restrict the retrieved list of transactions to the specified single transaction status.

The Inactive Returns field will allow members to retrieve the inactive (cancelled) transactions related to the Term DBV. By default, these will not be included. To include them, members should set the Inactive Returns field to indicate ‘Yes’.

Members will have the following selection criteria for the file transfer enquiry:

- Origin Transaction ID (optional)
- Origin Transaction Reference (optional)
- Date Range fields (optional)
- Inactive Returns (optional)

If neither Origin Transaction ID or Origin Transaction Reference is specified, the file transfer enquiry will retrieve details of all the Term DBVs for the member.

The response message to the enquiry will return the following details of the transactions related to the specified Term DBV:

- Origin Transaction ID (*Transaction Id of TDO*)

- Origin Transaction Reference (*Transaction Reference of TDO*)
- Transaction ID
- Transaction Reference
- Transaction Type
- Transaction Status
- Intended Settlement Date

Transaction Management functions

Members will be able to use the existing CREST system transaction enquiry functionality, both file transfer and the interactive GUI (ATXL/ATXQ, ATXR, and NDSR) for the new TDA transaction type.

Members will not be able to amend, delete or split the TDA transactions (as they are settled on successful processing of the TDA instruction).

Section 16: Valuation of DBVs using Bank of England Haircuts

With the introduction of the Term DBV service, the DBV functionality will additionally be enhanced to provide an option for members to apply a BoE Haircut to a DBV (Overnight and Term DBVs).

The BoE Haircut option will be available in relation to gilt-only DBVs (and only for gilts that are defined as eligible for the Self-Collateralising Repo service with the Bank of England). It will allow members to value gilt DBVs using the BoE Haircut rates⁷⁵ instead of a DBV Margin. Members will be able to specify either the BoE Haircut or the DBV Margin option, but not both.

The end effect of applying a BoE Haircut or a DBV Margin is the same: both will provide the Collateral Taker with additional collateral on top of what was requested by the **DBV Value Sought** amount. However, the two options will differ in the following ways:

- The **DBV Margin** is a single percentage value: during DBV collateral allocation, the same margin will be applied to each of the different lines of securities considered (i.e. the single margin value applies to the whole DBV). The DBV allocation process applies the margin by incrementing the ‘DBV Value Sought’ amount with the margin percentage and then attempting to seek appropriate collateral totalling this amount.
- The **BoE Haircut** is a variable percentage rate and, in contrast to DBV margin, the rate specifies the reduction that must be applied to the price in valuing the security (gilt) to which the rate relates. The applicable BoE Haircut rate is dependent on the individual gilt and its length of time to maturity (see table below).

Length of time to maturity (m)	Coupon paying security (Fixed Rate, Index Linked or Floating Rate)	Zero coupon security
	Haircut	Haircut
m ≤ 1 year	0.5%	0.5%
1 < m ≤ 3 years	1.5%	1.5%
3 < m ≤ 5 years	2.0%	2.0%
5 < m ≤ 7 years	3.0%	3.5%
7 < m ≤ 10 years	3.0%	3.5%
10 < m ≤ 20 years	4.5%	6.0%
20 < m ≤ 30 years	6.0%	8.5%
m > 30 years	7.5%	14.0%

Since the haircut rate varies between the different lines of gilt, a single value cannot be applied at the level of the whole DBV; instead the appropriate haircut rate must be applied at the level of each individual line of gilt. The DBV allocation process will calculate the adjusted market value of each different line of gilt (using the appropriate haircut percentage) and attempt to allocate the collateral such that the total of the **adjusted market values** of all the selected lines of gilt will equal the specified ‘DBV Value Sought’ amount.

DBVs set up to use the BoE Haircut are deemed to be correctly collateralised where the adjusted market value of the total collateral in the Term DBV is equal to the DBV Value Sought.

⁷⁵ The haircut rates used will be the same as those that were introduced for use with SCR margins in an earlier enhancement of the CREST system.

DBV Instruction Input

To allow valuation of DBVs by use of BoE Haircuts, the **DBV Input Instruction (NDDN)** message will be enhanced (for both the interactive GUI and file transfer) to include a new field, called ‘**Apply BoE Haircut**’.

The **Apply BoE Haircut** field will be a flag indicating that collateral valuation of a DBV must be calculated by applying the appropriate BoE Haircut rates associated to the collateral securities. The field will be matching, both parties must match the field exactly (if either party inputs it) and therefore it will not match to a blank.

Members will not be able to use the **Apply BoE Haircut** in combination with the **DBV Margin** option (i.e. the two fields are mutually exclusive).

The ‘Apply BoE Haircut’ option will be available for set up of gilt only DBVs. Members will only be able to select the haircut option in combination with one of the following **DBV Class** values:

- UBG - Unstrippable British Government Debt
- TSY - Treasury Bills
- ELG - OMO eligible bills
- BGS - All British Government Securities
- UGO - Unstripped British Government Stock (*new*)⁷⁶
- BEB - BoE Bills (TBC by BoE)
- TSB - Treasury & BoE Bills (TBC by BoE)

DBV Instruction Details enquiry

The **DBV Instruction Retrieve Details (NDDQ/NDDR)** enquiry for file transfer and the interactive GUI will be enhanced to report the new **Apply BoE Haircut** field.

DBV Stock Allocation

The DBV stock allocation process will follow the standard DBV allocation rules, however where the ‘Apply BoE Haircut’ option has been specified, the process will differ as follows:

- Any securities for the specified account/DBV class that are not eligible for use with the Self-Collateralising Repo service with the Bank of England will be excluded from the allocation process
- Allocation of collateral to meet the specified ‘DBV Value Sought’ amount will be based on the adjusted market value of the securities (i.e. the securities selected will be valued taking account of the applicable BoE Haircut rate).

DBV Stock Valuation

The **DBV Stock Valuation Total (NVTQ/NVTR)** file transfer and the interactive GUI enquiries will be enhanced as follows:

- The **Apply BoE Haircut** field will be added as additional selection criteria. The field will be optional, but members will not be able to select ‘Apply BoE Haircut’ in combination with the ‘DBV Margin’ selection criteria (the two fields will be mutually exclusive). Additionally,

⁷⁶ The UGO is a new DBV Class that will contain Unstripped British Gilts only. It is being introduced in conjunction with the Term DBV service to help support the Bank of England open market operations.

members will only be able to select the ‘Apply BoE Haircut’ option for certain ‘DBV Class’ values (refer to DBV Instruction Input paragraph above)

- If the ‘Apply BoE Haircut’ criteria has been specified:
 - the **Total Stock Value** reported will be the adjusted market value i.e. the stock value of each security balance in the specified account/DBV class will be calculated using the appropriate BoE Haircuts
 - any securities for the specified account/DBV class that are not eligible for use with the Self-Collateralising Repo service with the Bank of England will be excluded from the calculation of the **Total Stock Value**.

Note: the DBV Stock Valuation Detail (NVDQ/NVDL) file transfer and the interactive GUI enquiries will not be impacted by this change.

Collateral Instruction List enquiry

The **Collateral Instruction List (ARPQ/ARPL)** file transfer and the interactive GUI enquiries will be enhanced as follows:

- They will be updated to report the new **Apply BoE Haircut** field
- For Term DBVs that have been set up to use the BoE Haircut option, **Base Collateral Value** and **Last Collateral Value** will show the adjusted market values, i.e.:
 - ‘Base Collateral Value’ will show the same value as ‘Base Value Sought’ of the Term DBV.
 - ‘Last Collateral Value’ will show the current market value of the Term DBV collateral (excluding the extra collateral needed to satisfy the applicable BoE Haircut) based on the last reference prices available on the CREST system.

The file transfer enquiry (ARPQ) which also reports the Concentration percentage of each Term DBV constituent, will report the ‘Concentration’ based on the adjusted market value of the collateral securities. The ‘Concentration’ will show the adjusted market value of a constituent security as a percentage of the **Base Value Sought** of the Term DBV.

Additionally, to accommodate the haircut changes, the following two GUI screens relating to the interactive enquiry (ARPL) will be updated as indicated:

- The Collateral Instruction List screen will be updated to remove the display of the DBV Margin field (this will now be shown instead by the Collateral Instruction Detail screen)
- The Collateral Instruction Detail screen will be updated to display the following two additional fields; Apply BoE Haircut and DBV Margin

Note: These are changes to the GUI screen only, and does not affect the GUI messages apart from as already indicated earlier.

Collateral Return List enquiry

The **Collateral Return List (ARRL)** enquiry will be enhanced such that:

- For Term DBVs that have been set up to use the BoE Haircut option, the enquiry will report the ‘Concentration’ percentage based on the adjusted market value of the collateral security. The ‘Concentration’ will show the adjusted market value of a constituent security as a percentage of the **Base Value Sought** of the Term DBV.

Exposure Enquiries

The exposure enquiries (**BESQ/BESR** and **BEDQ/BEDL**) will not be updated for the BoE Haircut

changes. The exposure will continue to be calculated using the actual stock value based on the reference price as currently.

This means that for Term DBVs which have been set up to use the BoE Haircut option, the enquiry will always show an exposure on the side of the Collateral Giver (unless of course the Term DBV is disproportionately under-collateralised in comparison to the adjusted market value).

Manual Substitution of Term DBV Collateral

In addition to the changes described in Section 7, the manual substitution functionality (**Repo Substitution Input - ASBN**) will be further enhanced as follows to support the BoE Haircut change. For Term DBVs that are set up to use the BoE Haircut option:

- members will not be allowed to add or substitute in a security which is not eligible for use with the Self-Collateralising Repo service with the Bank of England
- if the substitution instruction is to add /substitute in a security to a Term DBV, but the Quantity (to be added) has not been specified, the system will calculate the quantity such that Term DBV will be correctly balanced; taking into account the adjusted market value of any stock being removed (using current prices with the appropriate haircut percentages) and calculating the quantity required using the adjusted market value (i.e. value after haircut) of the stock being added/substituted in.

Intraday Substitution of Term DBV Collateral

The intraday TDG substitution process (described in Section 8) will be enhanced for the BoE Haircut change as follows. For Term DBVs that are set up to use the BoE Haircut option:

- The value of the security being returned to the collateral giver (i.e. security being recalled to settle a failing transaction) will be calculated using the appropriate haircut applicable for that security
- The quantity of each replacement security required will be calculated on the basis of the adjusted market value of the security (i.e. value after haircut). **Note:** securities not eligible for use with the Self-Collateralising Repo service with the Bank of England will be excluded from being selected as replacement collateral
- For the TDG substitution to be generated, the Collateral Giver must have sufficient replacement collateral (based on the adjusted market value) equal to the adjusted market value of the security being recalled
- If Concentration Limit is applicable, the concentration for a constituent security will be calculated on the basis the adjusted market value of the security as a percentage of the **Base Value Sought** of the Term DBV. The substitution process will ensure that any replacement security selected will not lead to a breach of the concentration limit
- The settlement of a TDG substitution results in the deletion and/or creation of TDRs for the Term DBV. If there is a consideration, then the consideration on the TDRs that are deleted is re-apportioned across any new TDRs that are created. The re-apportionment of this consideration will be based on the adjusted market value of the security in a TDR as a proportion of the total adjusted market value of all the new TDRs created.

Overnight Substitutions

The overnight TDE substitution process (described in Section 8) will be enhanced for the BoE Haircut change as follows. For Term DBVs that are set up to use the BoE Haircut option:

- The value of the security being returned to the collateral giver (i.e. security being substituted out) will be calculated using the appropriate haircut applicable for that security
- The quantity of each replacement security required (i.e. security being substituted in) will be calculated on the basis of the adjusted market value of the security. **Note:** Securities not

eligible for use with the Self-Collateralising Repo service with the Bank of England will be excluded from being selected as replacement collateral

- For the TDE substitution to be generated, the Collateral Giver must have sufficient replacement collateral (based on the adjusted market value) equal to the adjusted market value of the security being substituted out
- If Concentration Limit is applicable, the concentration for a constituent security will be calculated on the basis the adjusted market value of the security as a percentage of the **Base Value Sought** of the Term DBV. The substitution process will ensure that any replacement security selected will not lead to a breach of the concentration limit
- The settlement of a TDE substitution results in the deletion and/or creation of TDRs for the Term DBV. If there is a consideration, then the consideration on the TDRs that are deleted is re-apportioned across any new TDRs that are created. The re-apportionment of this consideration will be based on the adjusted market value of the security in a TDR as a proportion of the total adjusted market value of all the new TDRs created.

Mark-to-Market Adjustments

The overnight TDM mark-to-market adjustment process (described in Section 9) will be enhanced for the BoE Haircut change as follows. For Term DBVs that are set up to use the BoE Haircut option:

- To determine if the Term DBV is over- or under-collateralised, the current total value of the Term DBV collateral (inclusive of any generated TDE substitutions) will be calculated using the adjusted market values
- If Concentration Limit is applicable, the concentration for a constituent security will be calculated on the basis the adjusted market value of the security as a percentage of the **Base Value Sought** of the Term DBV. The substitution process will ensure that any replacement security selected will not lead to a breach of the concentration limit
- The value of any security being returned to the collateral giver (i.e. security being removed) will be calculated using the appropriate haircut applicable for that security
- The quantity of any security being added to the Term DBV will be calculated on the basis of the adjusted market value of the security. **Note:** Securities not eligible for use with the Self-Collateralising Repo service with the Bank of England will be excluded from being selected
- The settlement of a TDM substitution results in the deletion and/or creation of TDRs for the Term DBV. If there is a consideration, then the consideration is re-apportioned across all the TDR transactions. This re-apportionment of the consideration will be based on the adjusted market value of the security in a TDR as a proportion of the total adjusted market value of all the TDRs relating to the Term DBV.

Re-apportionment of Term DBV consideration

Once security price changes have been applied as part of the overnight process, Term DBVs that have not reached their return date are assessed to re-apportion the original consideration (if any) on each of the Term DBVs across all its relating TDRs. The re-apportionment seeks to ensure that the consideration on each TDR is a fair reflection of the actual relative value of the collateral in that TDR in comparison to the total Term DBV collateral value. For Term DBVs that are set up to use the BoE Haircut option, the valuation of the collateral (i.e. both the value of the collateral in TDRs and the total Term DBV collateral value) will be based on the appropriate haircuts (i.e. the re-apportionment will be based on the adjusted market values of the collateral).